



AMKmotion
Device description
Motor encoders

Version: 2022/49

Part no.: 27859

Translation of the "Original Dokumentation"

AMK*motion*

MEMBER OF THE ARBURG FAMILY

Imprint**Name:** PDK_027859_Motorgeber**Version:**

Version: 2022/49	
Change	Letter symbol
<ul style="list-style-type: none">• AMKmotion design	LeS

Previous version: 2020/04**Copyright notice:**

© AMKmotion GmbH + Co KG

Any transfer or reproduction of this document, as well as utilisation or communication of its contents, requires express consent. Offenders are liable for the payment of damages. All rights are reserved in the event of the grant of a patent or the registration of a utility model or design.

Reservation:

We reserve the right to modify the content of the documentation as well as the delivery options for the product.

Publisher:

AMKmotion GmbH + Co KG
Gaußstraße 37-39
73230 Kirchheim unter Teck
Germany

Phone +49 7021 50 05-0

Fax +49 7021 50 05-176

E-mail: info@amk-motion.com

Registration court: AG Stuttgart, HRA 230681, Kirchheim unter Teck,

Tax Id no.: DE 145 912 804

Complementary: AMKmotion Verwaltungsgesellschaft mbH, HRB 774646

Service:

Phone +49 7021 50 05-190, Fax -193

For fast and reliable troubleshooting, you can help us by informing our Customer Service about the following:

- Type plate data for each unit
- Software version
- Device configuration and application
- Type of fault/problem and suspected cause
- Diagnostic messages (error messages)

E-mail service@amk-motion.com**Internet address:**www.amk-motion.com

Content

Imprint	2
1 About this documentation	5
1.1 Structure of this document	5
1.2 Keeping this document	5
1.3 Target group	5
1.4 Purpose	5
1.5 Display conventions	6
1.6 Appendant documents	6
2 For your safety	7
2.1 Basic notes for your safety	7
2.2 Safety rules for handling electrical systems	7
2.3 Intended use	7
2.4 Requirements for the personnel and their qualification	7
2.5 Warranty	8
3 Basics	9
3.1 Tasks of an encoder system	9
3.2 Measurement procedure	9
3.2.1 Analog measurement (SIN/COS track)	9
3.2.1.1 Homing signal	9
3.2.2 Digital measurement	10
3.2.3 Absolute value generation	10
3.2.3.1 Singleturn measurement value recording	10
3.2.3.2 Multiturn measurement value recording	10
3.3 Measurement principles	11
3.3.1 Optical encoder	11
3.3.2 Inductive encoder	11
3.3.3 Resolver	13
3.3.4 Hall sensor	14
3.3.5 Capacitive encoders	14
4 Encoder types	15
4.1 Overview of AMK motor encoders	15
4.1.1 Controller support	16
4.2 Description of the encoder types	16
4.2.1 A-encoder	16
4.2.2 B- / C-encoder	18
4.2.3 E- / F-encoder	19
4.2.4 H-encoder (Hall sensor)	20
4.2.5 I-encoder	20
4.2.6 P- / Q-encoder	22
4.2.7 R-encoder (resolver)	24
4.2.8 S- / T-encoder	25
4.2.9 U- / V-encoder	27
4.2.10 Y-encoder	28
4.3 Encoder type in the motor designation	29
5 Encoder interfaces in AMK converters	30
5.1 [X130] resolver / Hall encoder	30
5.2 [X131] sine encoder	31
5.3 [X05] Encoder connection	35
6 Notes on startup for encoders	39
6.1 Electronic type plate (encoder with internal memory)	39
6.2 Parameterization	39

Glossary

40

Your opinion is important!

44

1 About this documentation

1.1 Structure of this document

Topic	Chapter	Chapter number
Validity, use and the purpose of the document	Imprint	-
	About this document	1
Safety	For your safety	2
Information on the function of motor encoders <ul style="list-style-type: none"> • Measurement procedures • Measurement principles 	Fundamentals	3
Information on the encoders used by AMK	Encoder types	4
Information on the encoder interfaces of the AMK controllers	Encoder interfaces in AMK converters	5
Notes on startup	Notes on startup for encoders	6
Abbreviations and explanation of terms	Glossary	-

1.2 Keeping this document

This document must permanently be available and readable at the place where the product is in use. If the product is used at another place or changed the owner, the document must be passed on.

1.3 Target group

Any person that is qualified and intends to work with this product must read, understand and follow this document:

- Transportation and storage
- Unpacking and installation
- Projecting
- Connection
- Parameterization
- Startup
- Service and repair
- Decommissioning and disposal
- Replacement

1.4 Purpose

This document describes the characteristics of the encoders that are built into AMK motors.

This document is addressed to any person who handles the product. It gives information about the following topics:

- Safety messages which are absolutely necessary to take care of during handling the product
- Product identification
- Projecting, planning and dimensioning of the application
- Environmental conditions for storage, transportation and operation
- Assembly
- Electrical connections
- Startup and operation
- Replacement
- Diagnosis
- Decommissioning and disposal
- Technical data

1.5 Display conventions

Display	Meaning
	This symbol points to parts of the text to which particular attention should be paid!
0x	0x followed by a hexadecimal number, e. g. 0x500A
'Names'	Names are represented with apostrophes e. g. parameters, variables, etc.

1.6 Appendant documents

Device descriptions

Part no.	Titel
29881	Controller cards KW-R03 / -R03P / -R04
202184	Controller card KW-R05
202276	Motors DD / DT / DTG / DTK / DP
202744	Controller cards KW-R06 / -R16 / -R07 / -R17
203445	Decentralized drive technology iC / iX / iDT5
204918	Controller cards KW-R24(-R) / -R25 / -R26 / -R27
	Motor data sheets

Functional documentations

Part no.	Titel
26249	Parameter description KW-R03 / -R03P / -R04
204979	Software description AIPEX PRO V3 (PC software for startup and parameterization)
203704	Parameter description KW-R06 / -R16 / -R07 / -R17 / KW-R24(-R) / -R25 / -R26 / -R27 / iC / iX / iDT5

2 For your safety

2.1 Basic notes for your safety

- At electrical drive systems, hazards are present in principle that can result in death or fatal injuries:
 - Electrical hazard (e. g. electric shock due to touch on electrical connections)
 - Mechanical hazard (e. g. crush, retract due to the rotation of the motor shaft)
 - Thermal hazard (e. g. burns due to touch on hot surfaces)
- These hazards are present while starting up and operating the unit, and also during servicing or maintenance work.
- Safety instructions in the documentation and on the product warn about the hazards.
- Personnel must have read and understood the safety instructions before installing and operating the product. In the documentation about the product the usage warnings pertain to direct hazards and must therefore be followed directly when operating or handling the product by the operator.
- AMKmotion products must be kept in their original order, that means it is not allowed to do a significant constructional change on hardware side and software is not allowed to be decompiled and change the source code.
- Damaged or faulty products are not allowed to be integrated or put into operation.
- Do not start the system in which the AMKmotion products are installed (begin of intended use) until you can determine that all relevant standards, laws, and directives have been complied with, e. g. low voltage directive, EMC directive, and the machinery directive, and possible further product standards. The plant manufacturer is responsible for the compliance with the laws, directives, and standards.
- The devices must be installed, electrically connected and operated as shown in the device description documentation. The technical data and the required environmental conditions must be observed at all times.

2.2 Safety rules for handling electrical systems

In particular on drive systems, the instructions pertaining to safety and the following five safety rules have to be kept in the specified sequence:

1. Switch off electrical circuits (also electronic and auxiliary circuits).
2. Secure against being switched on again.
3. Determine that there is no voltage.
4. Ground and short circuit.
5. Cover or close off neighboring parts that are under voltage.

Reverse the measures taken in reverse order after completing the work.

2.3 Intended use

Motor encoders record the rotor position of the servo motor and report it to the controller, which generates actual position and speed values from it. For synchronous motors, the rotor position is used to energize the motor correctly. The motor encoder is built into the motor housing at the motor's B-bearing and connected to the motor shaft.

2.4 Requirements for the personnel and their qualification

Only authorized and qualified personnel may work on and with the AMKmotion drive systems.

Specialised personnel must:

- Perform mechanical and electrical work that is described in this documentation, such as mounting and connecting
- Observe all information in the documentation accompanying the product in order to work with the product safely and in an error-free manner
- Understand and know hazards that occur when handling the product
- Know connections and functions of the system
- Be familiar with the control concept in order to operate the drive system
- Be authorized to switch circuits and devices on and off, ground and label them
- Observe local specific safety requirements

2.5 Warranty

- All information in the documents accompanying the product must be complied with for a safe and trouble-free operation.
- The assertion of warranty claims is excluded if the information in the documents is not observed completely.
- Hardware and firmware may not be modified except by personnel authorized by AMKmotion and after consultation with AMKmotion.
- The company AMKmotion GmbH + Co KG is not liable for damages from unintended use, incorrect installation or operation, exceeding rated values and non-observance with the environmental conditions.

3 Basics

3.1 Tasks of an encoder system

The main task of the motor encoder is to report the rotor position back to the inverter. For the field-oriented control, the current setpoints and the current commutation from the rotor position are calculated.

Sufficient for control of an asynchronous motor is incremental evaluation of the rotor position, in which position changes are recorded as relative but there is no absolute position reference.

A synchronous motor demands an absolute measurement system that is oriented on the poles of the permanent magnets in the rotor.

From the encoder signals, the evaluation electronics generate the actual speed and position value for drive control.

3.2 Measurement procedure

3.2.1 Analog measurement (SIN/COS track)

Analog encoder systems provide sine and cosine signals, which are output as difference signals.

The position of the rotor cannot be uniquely determined with a single sine signal. Two sensors, electrically offset by 90° are used that generate a sine and a cosine signal. Through evaluation of both signals, the rotor position and direction of rotation can be uniquely determined.

If an encoder provides exactly 1 SIN/COS period per revolution (e.g. resolver), the position within a revolution can be determined absolutely (single turn absolute encoder).

If there are several SIN/COS periods per revolution (e.g. I-encoder), only a relative movement of the rotor can be determined. (Incremental evaluation)

For position control over more than one SIN/COS period, the position reference between the rotor position and machine must be created by the user with a homing cycle. To do this, these encoders have a homing pulse that, together with a cam signal at the machine, defines the machine zero point in the homing cycle. After the homing cycle, the actual position value is continuously determined in the drive controller with the SIN/COS tracks.

For correct commutation in synchronous motors, the resolver must be tuned after assembly to the motor shaft. The commutation offset determined in encoder tuning is stored in the parameter record (ID32959 'Offset resolver').

Through the following events, the stored commutation offset gets lost or is no longer valid:

- The encoder changes its position to the motor shaft
- The initial program loading of the parameters function is executed
- A parameter record is written and overwrites the stored value

In these cases, the commutation offset must be newly determined, or the motor will not be controllable!

3.2.1.1 Homing signal

To determine the position, a reference is required between drive and machine. The reference point is made with a homing cycle, which evaluates the position of a homing signal.

To do this, analog encoders can have an additional track, which provides a homing mark. The absolute position determined with the homing mark (related to 1 revolution) is assigned to exactly one measurement step.

And so before an absolute reference is created or the last selected reference point is found again, the homing mark must be run over. In the least favorable case, this requires a turn of up to 360°.

Example: optical analog encoder with homing signal:

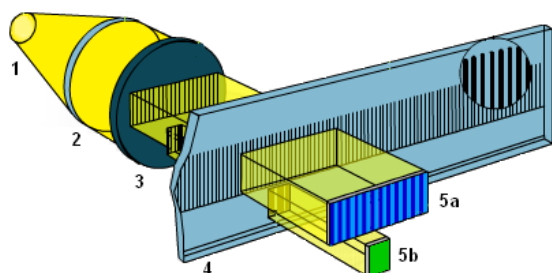

- 1 Light source
- 2 Collector
- 3 Screen
- 4 Glass element (signal encoder)

Sensors

- 5a SIN/COS track
- 5b Homing signal

(Illustration from <http://content.heidenhain.de/presentation/basics/de>)

3.2.2 Digital measurement

Digital encoder systems make the rotor position available as an absolute value through various interfaces (e.g. EnDat, Hiperface). For correct commutation in synchronous motors, the encoder must be tuned after mounting to the motor shaft. For encoders with encoder memory, the commutation offset determined during encoder tuning is stored in the encoder. If the position of the encoder in relation to the motor shaft changes (e.g. with encoder replacement), the commutation offset must be newly determined, or the motor will not be controllable. AMK motors with absolute value encoder and encoder storage are tuned at the factory and shipped with a valid commutation offset.

3.2.3 Absolute value generation

The absolute position information is determined from the code tracks of the encoder.

In the absolute measurement procedure, the position value is available immediately after the encoder is switched on and can be read by the controller at any time. The motor shaft does not have to be moved to determine the actual position value.

The following illustration shows as an example an optical absolute measurement with a resolution of 4 bits.

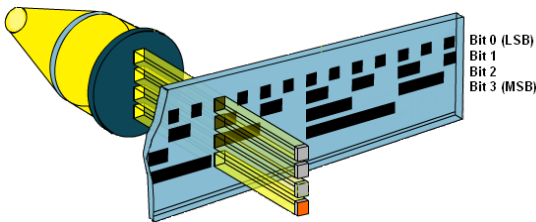

(Illustration from <http://content.heidenhain.de/presentation/basics/de>)

3.2.3.1 Singleturn measurement value recording

Singleturn absolute value encoders resolve the position within a rotation and then restart at 0.

Through a singleturn encoder, a coded position value is assigned to every angle position. That means, the angle of rotation within a rotation is known.

Before the axis may be driven in position loop operation, a homing cycle in the drive must be called up for the singleturn encoder. The required homing mark of the encoder is formed in the drive controller.

(See document Function description 'Homing cycle')

For the absolute position to remain known after several rotations, the rotations must also be counted by the controller. The controller must save this value at switch-off. It must also be ensured that the measurement system is not readjusted after switch-off.

3.2.3.2 Multiturn measurement value recording

Multiturn absolute value encoders can resolve the position of the rotor over several rotations.

Through a multiturn encoder, a coded position value is assigned to every angle position and every complete rotation. A zero setting or homing is only necessary at the first startup.

For the absolute position to remain known after several rotations, the rotations in the measurement system must continue to be counted after switch-off as well.

To record the rotations, multiturn rotary encoders use several code discs, which are internally connected through a gear.

At startup, the working range of the multiturn encoder must be selected so that modulo transition of the rotations is reliably avoided, which means the drive must not leave the permitted working range or it will lose its absolute reference.

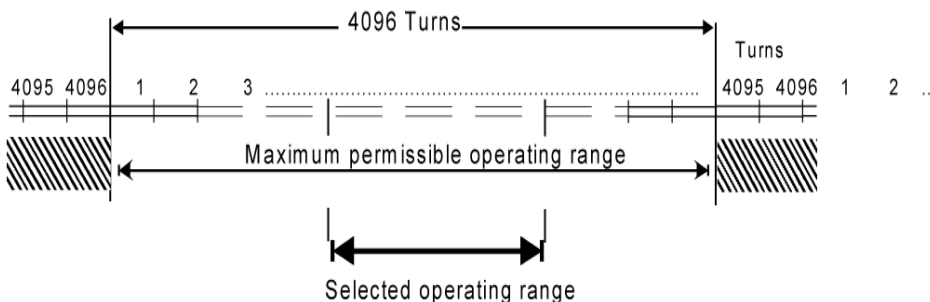

3.3 Measurement principles

3.3.1 Optical encoder

Optical encoders as signal encoders have a glass element (4) on which there is a pattern of transparent and opaque areas (lines). A light-sensitive sensor (5) records the intensity of the light beam dependent on the position of the glass element.

If the glass element as signal encoder moves relative to the sensor, this generates a sine-shaped periodic signal in the sensor.

The number of periods through a rotor rotation is decisive for the accuracy of the actual position value.

The position of the rotor cannot be uniquely determined with a single sine signal. Two sensors, electrically offset by 90° are used that generate a sine and a cosine signal. Through evaluation of both signals, the rotor position and direction of rotation can be uniquely determined.

Optical encoders can have very high resolutions but are susceptible to polluted environment due to dust and oil.

The following illustration shows the principle of an optical encoder.

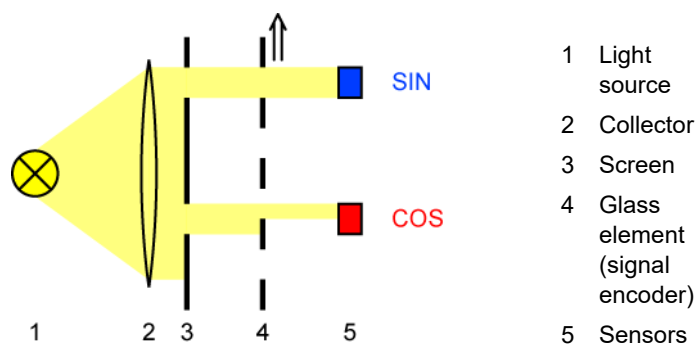

With this design, the following signal pattern results:

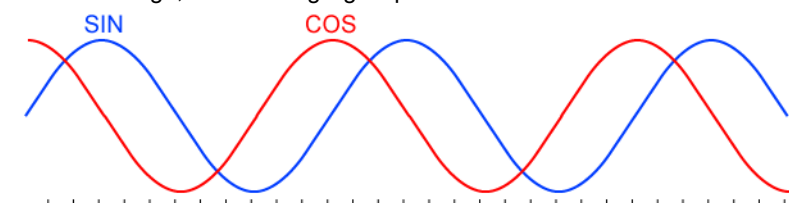

3.3.2 Inductive encoder

Inductive encoders contain a sensor and a signal encoder.

The signal encoder consists either of permanent magnets, which are aligned alternately, or of a magnetoresistor, in whose surface indentations have been made so that the permeability of the air gap changes cyclically.

The sensor records the strength of the magnetic field on the surface of the signal encoder and converts this information into electric signals.

If the signal encoder (magnetoresistor / permanent magnets) moves relative to the sensor, this generates a sine-shaped periodic signal in the sensor.

The number of periods through a rotor rotation is decisive for the accuracy of the actual position value.

The position of the rotor cannot be uniquely determined with a single sine signal. Two sensors, electrically offset by 90° are used that generate a sine and a cosine signal. Through evaluation of both signals, the rotor position and direction of rotation can be uniquely determined.

Inductive encoders are more robust against dust and oil contamination (except metal dust) but are more prone to magnetic disturbances and stray fields. The resolutions are lower than with optical encoders.

Encoder with permanent magnets

For encoders with alternately arranged permanent magnets, the sensor measures the strength of the magnetic field directly. Since these permanent magnets cannot be infinitely narrow, the achievable resolution is limited.

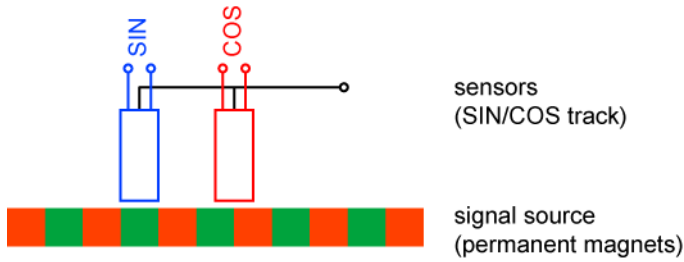

Encoder with magnetoresistor

The width of the air gap between sensor and signal encoder changes through the indentations of the signal encoder. This also changes the magnetic resistance, the permeability. The sensor detects the change in a magnetic field subject to this air gap.

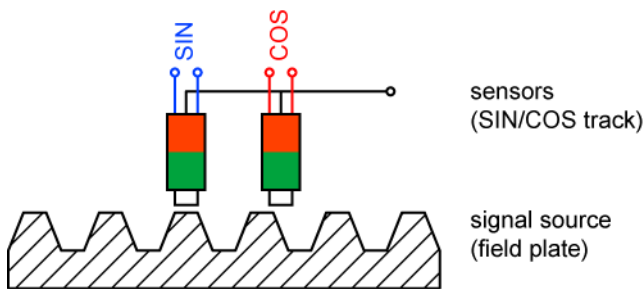

Homing signal

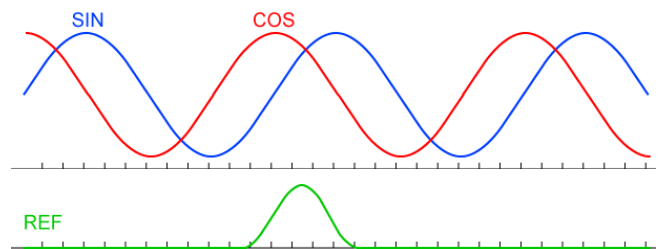
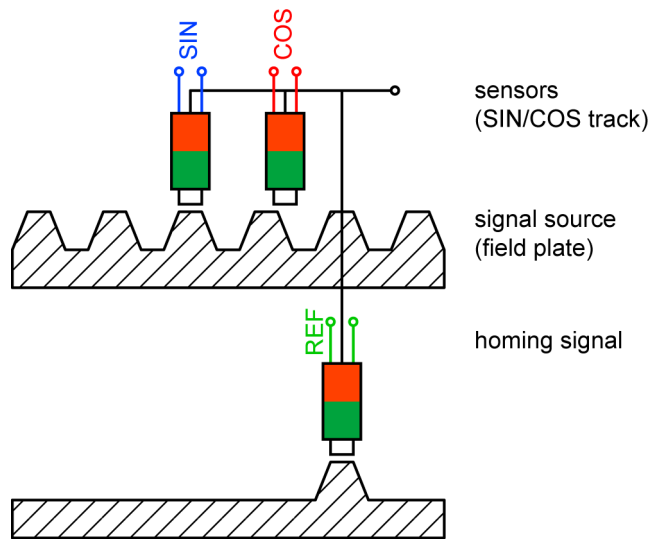
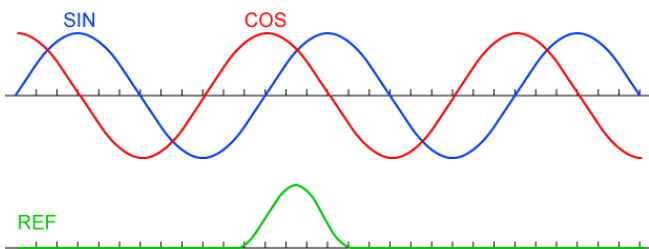
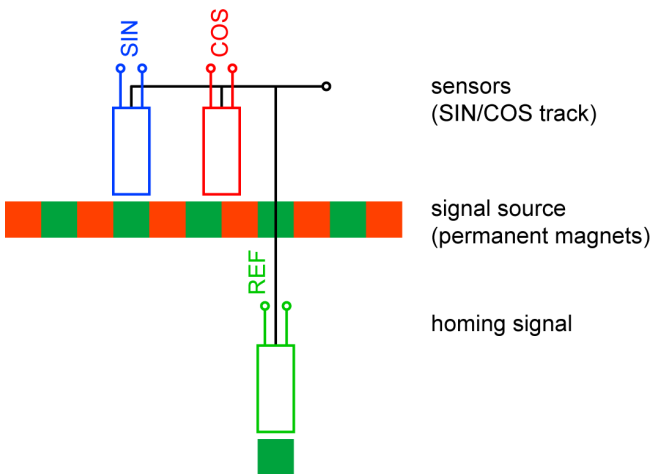

3.3.3 Resolver

The resolver is an inductive rotatory position encoder. It supplies an absolute position signal within a rotation (1 SIN/COS period/rotation).

The resolver contains the following windings:

- Exciter winding (stator)
- Secondary winding, connected with the rotor winding (rotor)
- Measurement winding 1 (SIN) and 2 (COS), offset by 90° electrically arranged (stator)

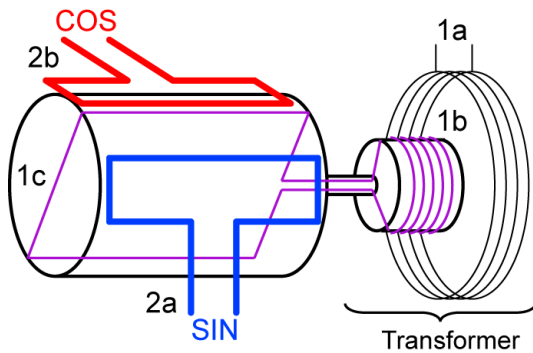

Rotary transformer

- 1a Exciter winding
- 1b Secondary winding
- 1c Rotor winding

Measurement windings

- 2a Measurement winding 1 SIN track
- 2b Measurement winding 2 COS track

The evaluation electronics energize the exciter winding with a high-frequency exciter signal. This signal is transmitted to the secondary winding in the rotor through the rotary transformer. The rotor is connected to the motor shaft. The secondary winding feeds the short-circuited rotor winding, through which a short-circuit current flows with the frequency of the exciter signal. This short-circuit current is surrounded by a magnetic field, which induces voltage in the measurement windings 1 and 2. This induced voltage has the same frequency and phasing as the exciter signal. The amplitudes of the voltages induced in the measurement windings are dependent on the position of the rotor:

- If the rotor and measurement winding are parallel to each other, the magnetic field of the rotor pushes through the measurement winding completely, and the induced voltage amplitude is at a maximum.
- If the rotor and measurement winding are perpendicular to each other, no voltage is induced in the measurement winding.

The amplitude of the induced voltage in each measurement winding is a sine function dependent on the position of the rotor shaft. The position of the rotor cannot be uniquely determined with a single sine signal. Two sensors, electrically offset by 90° are used that generate a sine and a cosine signal. Through evaluation of both signals, the rotor position and direction of rotation can be uniquely determined.

The signal of the measurement windings consists of the exciter signal with a superimposed envelope. The envelope must be extracted from the evaluation electronics and supplies the position signal.

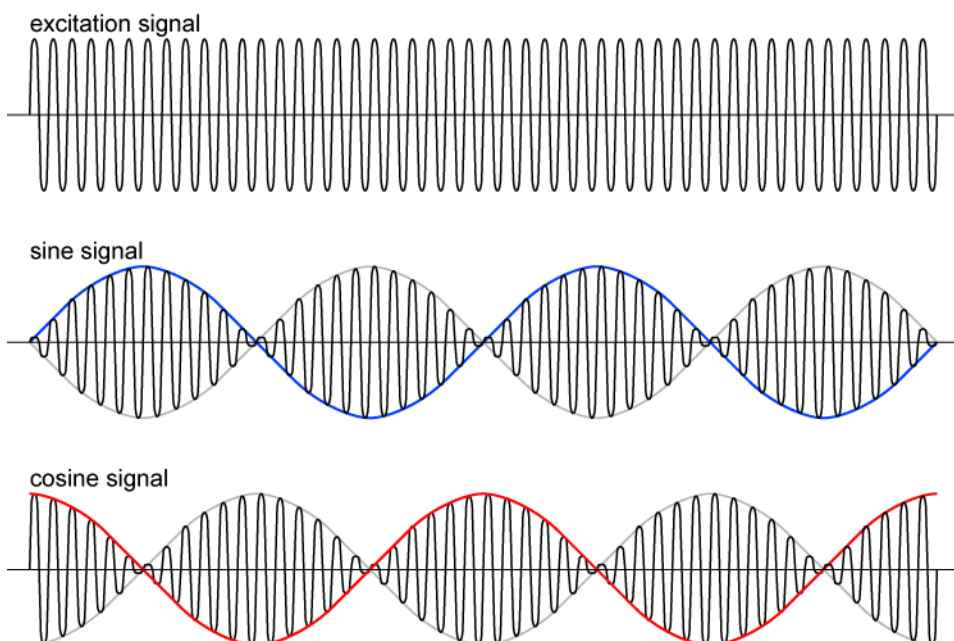

3.3.4 Hall sensor

If a current flows through a Hall sensor, and the Hall sensor is brought into a magnetic field running vertically to it, the sensor supplies an output voltage that is proportional to the product of the magnetic field strength and current (Hall effect).

The amplitude of the induced voltage U_H is a sine function dependent on the position to the magnetic field. The Hall sensor generates one sine period per pole pair.

A Hall sensor also supplies a signal when the magnetic field in which it is located is constant. This is the decisive advantage compared to a sensor that consists of magnet and coil. As soon as magnet and coil in this pairing are not moved against each other, the voltage induced in the coil is zero and the magnet is not detected.

The position of the rotor cannot be uniquely determined with a single sine signal. Two sensors, electrically offset by 90° are used that generate a sine and a cosine signal. Through evaluation of both signals, the rotor position and direction of rotation can be uniquely determined.

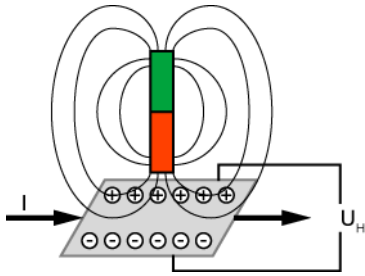

The following signal pattern results with one period per rotation:

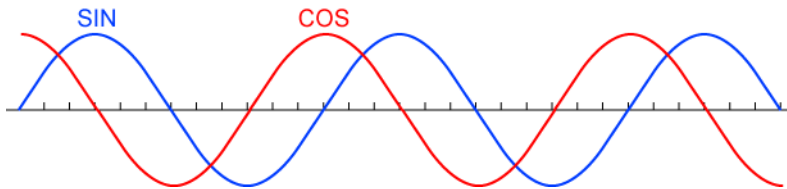

3.3.5 Capacitive encoders

Capacitive encoders consist of a signal encoder and a sensor with an electrical field between them.

A toothed rotor is moved in the gap of the sensor, which changes the dielectric.

The sensor detects the changing field strength and converts this information into electrical signals.

If the rotor moves between the signal encoder and sensor, this generates a sine-shaped periodic signal in the sensor.

The number of periods through a rotor rotation is decisive for the accuracy of the actual position value.

The position of the rotor cannot be uniquely determined with a single sine signal. Two sensors, electrically offset by 90° are used that generate a sine and a cosine signal. Through evaluation of both signals, the rotor position and direction of rotation can be uniquely determined.

Inductive encoders are more robust against dust and oil contamination. The resolutions are lower than with optical encoders.

Basic construction of a capacitive encoder:

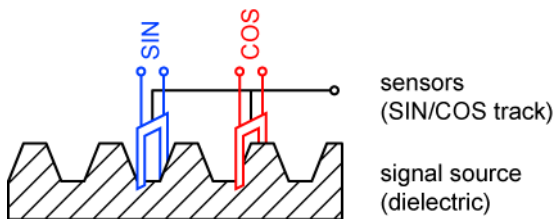

The following signal pattern results:

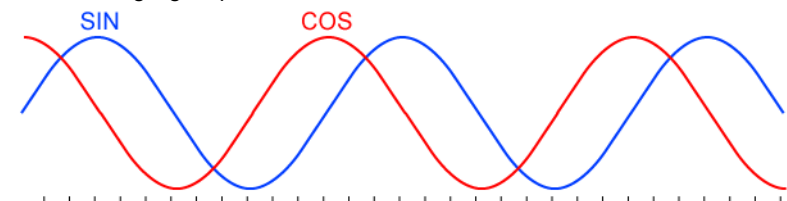

4 Encoder types

4.1 Overview of AMK motor encoders

Encoder type	Measuring method				Absolute		Interface / protocol					
	Optic.	Induct.	Resolver / Hall	Capac.	Single-turn	Multi-turn	Analog			Digital		EnDat
							Resolver	SIN/ COS	homing pulse	Hiper-face	Hiper-face DSL	
A		x						x	x			
B			x		x							
C			x			x						
E	x				x			x				2.1
F	x					x		x				2.1
H			x		x		x	(x) ¹⁾				
I	x							x	x			
P		x			x			(x) ²⁾				2.2 light 3)
Q		x				x		(x) ²⁾				2.2 light 3)
R			x		x		x					
S	x				x			x		x		
T	x					x		x		x		
U				x	x			x		x		
V				x		x		x		x		
Y	x				x	x					x	

1) With decentralized drives iC or iX, Hall type encoders are connected to the sine encoder interface
See document Device description Decentralized drive technology iC / iX / iDT5, Part no. 203445

2) The SIN/COS track will only be evaluated in combination with functional safety

3) Only the digital track is evaluated.

EnDat 2.2 light means, that the encoder supports EnDat 2.2, which is used only with the commands of EnDat 2.1 from the AMK controller.

4.1.1 Controller support

The encoder types can be evaluated with the following drive controllers:

Encoder evaluation	R27	R26	R25	R24-R	R24	R16 R17	R05 R06 R07	iDT(- R3) iX(-R3) iC(-R3)	iDT iX iC
Resolver (R-encoder)	-	-	-	■	-	-	■	-	-
Sine encoder (I-encoder)	■	■	■	-	-	■	■	■ ²⁴⁾	■ ²⁴⁾
EnDat 2.1 (E-/F-encoder)	■	■	■	-	-	■	■	■	■
Hiperface (S-/T-type)	■	■	■	-	-	■	■	■	■
Hiperface (U-/V-encoder)	■	■	■	-	-	■	■	■	■
Hiperface DSL (Y-encoder)	■	■	-	-	-	-	-	-	-
EnDat 2.2 light (P-/Q-encoder)	■ ²⁰⁾	■ ²⁰⁾	■ ²⁰⁾	-	-	■ ²⁰⁾	■ ²⁰⁾	■ ²⁰⁾	■ ²⁰⁾
Hall sensor (H-encoder)	-	-	-	-	-	-	■ ³⁰⁾	■ ³¹⁾	■ ³¹⁾
Square wave pulse interface (input / forward) ¹⁾	-	-	-	-	-	-	■ ²⁾	-	-
2nd encoder e.g. load encoder	-	-	-	-	-	-	■	-	-

RTE Real-time Ethernet

SM Synchronous machine

1) The square wave pulse interface can alternatively be parameterized as input or to forward the signals

2) 5 V level track A and B differential

20) Only the digital track is evaluated.

EnDat 2.2 light means, that the encoder supports EnDat 2.2, which is used only with the commands of EnDat 2.1 from the AMK controller.

24) Encoder interface with external hardware support (Level adaption circuit for sine/cosine to 1.2 V peak-peak

30) Connection via resolver input X130 connector 8: GND, connector 9: 5 VDC

31) Connection via sine encoder input

32) The controller card supports 3 multifunctional BI/O (BI/O1 to 3). Each BI/O can be used either as binary input or binary output.

4.2 Description of the encoder types

4.2.1 A-encoder

The following data are typical guidelines and can therefore deviate for the specific motor.

Encoder type	Technical description	Manufacturer / designation
A	<ul style="list-style-type: none"> Analog encoder (Siehe Seite 9.) Homing pulse (Siehe Seite 9.) 	AMK
	Resolution: 50 / 100 periods/revolution ²⁾	
	Measuring principle: inductive, magneto resistor (Siehe Seite 11.)	

2) depends on motor size

Principle

A measurement gear on the motor shaft (B-bearing side) with a separate gear tooth for the homing pulse damps three differential magnetoresistors, which are arrayed on the perimeter. Each tooth causes a sine-shaped voltage change in the assigned magnetoresistor.

In encoder assembly at the factory, the magnetoresistors are adjusted so that two sine signals (SIN/COS) offset by 90° and a homing pulse are output, each as a difference signal.

Output signal

Signal sequence depicted for clockwise turning of the motor shaft with direction of view toward the A bearing side of the shaft. (at 20 °C)

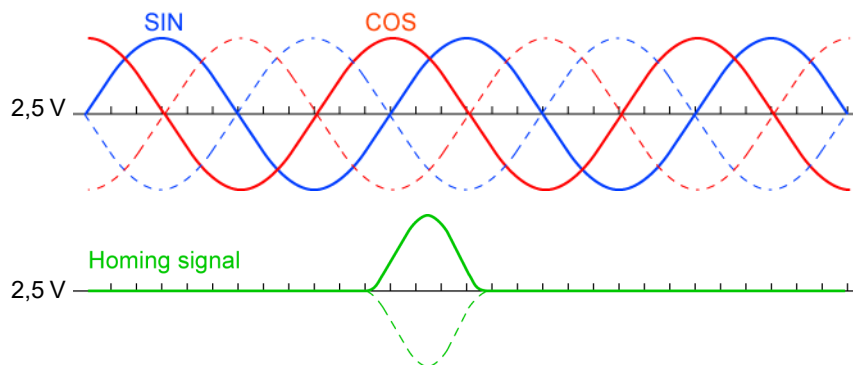

Technical data of the encoder

Data		A-encoder
Analog signals (SIN/COS)		
Resolution	Per./rotation	50 / 100
Signal level	mV _{SS}	160 ±16
Offset	V	2.5 ±0.5
Phase angle	° el.	90 ±10
Homing signal		
Signal level	mV _{SS}	500 ±20
Offset	V	2.5 ±0.5
Max. mech. speed	1/min	60000

Note on startup

The basic encoder tuning must be performed once at initial startup. Amplification, offset and phasing are fine-tuned using software.

The thus determined correction values are stored in the EEPROM on the inverter. After each replacement of the inverter or motor, basic encoder tuning must be performed again.

During operation, encoder tracking is active in the inverter. For example, the temperature influence on the output signals of the motor encoder is thereby compensated through the software.

4.2.2 B- / C-encoder

The following data are typical guidelines and can therefore deviate for the specific motor.

Encoder type	Technical description	Manufacturer / designation
B	<ul style="list-style-type: none"> • Absolute encoder (Siehe Seite 10.) • Singleturn (Siehe Seite 10.) • Analog (Siehe Seite 9.) 	AMK
	Resolution: 1 period/revolution	
	Measuring principle: Hall sensor (Siehe Seite 14.)	
C	<ul style="list-style-type: none"> • Absolute encoder (Siehe Seite 10.) • Multiturn (Siehe Seite 10.) • Analog (Siehe Seite 9.) 	AMK
	Resolution: 1 period/revolution	
	Measuring principle: Hall sensor (Siehe Seite 14.)	

Principle

A Hall sensor provides one SIN/COS period each within a rotation to determine position.

The firmware in the controller counts the rotations to generate a multiturn absolute value. To maintain the absolute value after the power supply is turned OFF, an uninterruptible power supply is required or the value must be stored by the controller in non-volatile memory.

B- and C-encoders are built into iDT4 drives.

Output signal

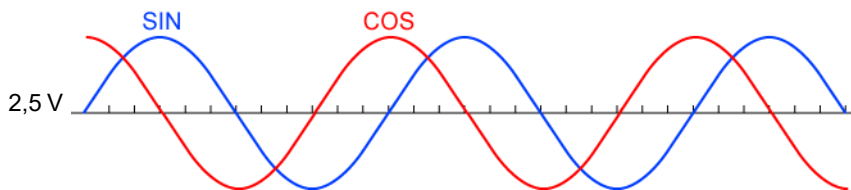

Startup

See document Product description Decentralized drive technology IDT4 (AMK part-no. 202092), chapter Functionality and commands, subtopic Absolute encoder.

4.2.3 E- / F-encoder

The following data are typical guidelines and can therefore deviate for the specific motor.

Encoder type	Technical description	Manufacturer / designation
E	<ul style="list-style-type: none"> • Absolute encoder (Siehe Seite 10.) • Singleturn (Siehe Seite 10.) • Digital (Siehe Seite 10.) • Analog (Siehe Seite 9.) 	Heidenhain ECN 113 ECN 1113 ECN 1313
	Digital resolution: 13 bit/revolution	
	Analog resolution: 512 / 2048 periods/revolution	
	Measuring principle: optical (Siehe Seite 11.)	
	Protocol: EnDat 2.1	
	Electronic type plate (Siehe Seite 39.)	
F	<ul style="list-style-type: none"> • Absolute encoder (Siehe Seite 10.) • Multiturn (Siehe Seite 10.) • Digital (Siehe Seite 10.) • Analog (Siehe Seite 9.) 	Heidenhain EQN 1125 EQN 1325
	Digital resolution: 13 bit/revolution	
	Analog resolution: 512 / 2048 Periods/revolution	
	Measuring principle: optical (Siehe Seite 11.)	
	Protocol: EnDat 2.1	
	Electronic type plate (Siehe Seite 39.)	

Output signal EnDat 2.1

The EnDat protocol transfers digital data between an encoder and the evaluation electronics according to the RS485 specification. The absolute positions are transferred synchronously to the cycle signal (CLOCK) specified by the evaluation electronics.

Output signal (SIN/COS track)

Signal sequence depicted for clockwise turning of the motor shaft with direction of view toward the A bearing side of the shaft.

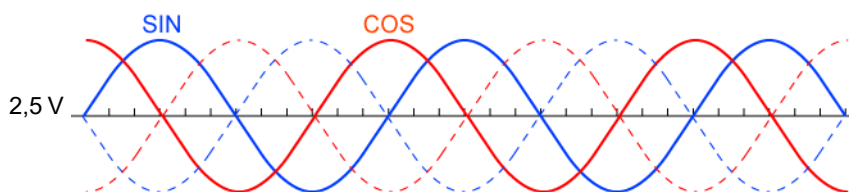

The encoders are temperature-compensated and deliver standardized output signals.

Technical data of the encoders

Data		E-encoder			F-encoder	
		ECN 113	ECN 1113	ECN 1313	EQN 1125	EQN 1325
Voltage supply	VDC	5 V ±5 %	3.6 - 14		3.6 - 14	
Current consumption without load (5 V)	mA	≤180	85		105	
Mechanically permitted speed	1/min	4000	12000	15000	12000	12000
Analog signals (SIN/COS)						
Analog resolution	Per./rotation	2048	512	512 / 2048	512	512 / 2048
Signal level	V _{SS}	1 ±0.2			1 ±0.2	
Offset	V	2.5 ±0.5			2.5 ±0.5	
Symmetry deviation			0.05		0.05	
Signal ratio			0.9 - 1.1		0.9 - 1.1	
Phase angle	° el.		90 ±0.5		90 ±0.5	
Absolute position values						
Signal characteristic		RS485			RS485	
Digital resolution	Pos./rotation	8192 (13 Bit)			8192 (13 Bit)	
Rotations		1			4096 (12 Bit)	

4.2.4 H-encoder (Hall sensor)

The following data are typical guidelines and can therefore deviate for the specific motor.

Encoder type	Technical description	Manufacturer / designation
H	<ul style="list-style-type: none"> Absolute encoder (Siehe Seite 10.) Singleturn (Siehe Seite 10.) Analog (Siehe Seite 9.) 	AMK
	Resolution: 1 period/pole pair	
	Measuring principle: Hall sensor (Siehe Seite 14.)	

Linear motors are often equipped with a Hall sensor, which provides per pole pair one sine and one cosine signal with 1 V_{SS}. This makes a unique determination of the commutation angle possible.

With limited accuracy and dynamics, the Hall encoder can also be used for speed and position control.

In combination with a linear measure, dynamic control without the software commutation function is possible.

4.2.5 I-encoder

The following data are typical guidelines and can therefore deviate for the specific motor.

Encoder type	Technical description	Manufacturer / designation
I	<ul style="list-style-type: none"> Analog encoder (Siehe Seite 9.) Homing pulse (Siehe Seite 9.) 	Heidenhain ERN 1380 ERN 1381
	Resolution: 512 / 1000 / 1024 / 2048 periods/revolution	
	Measuring principle: optical (Siehe Seite 11.)	

Principle

If an analog encoder has several SIN/COS periods per rotation, an absolute position reference within a motor rotation is possible. The rotor rotating field of the permanent magnets of a synchronous motor is not aligned on the stator rotating field. For synchronous motors with I encoder, alignment takes place automatically in the drive controller through the software commutation function after each power on and initial setting of the controller enable.

Output signals

Signal sequence depicted for clockwise turning of the motor shaft with direction of view toward the A bearing side of the shaft.

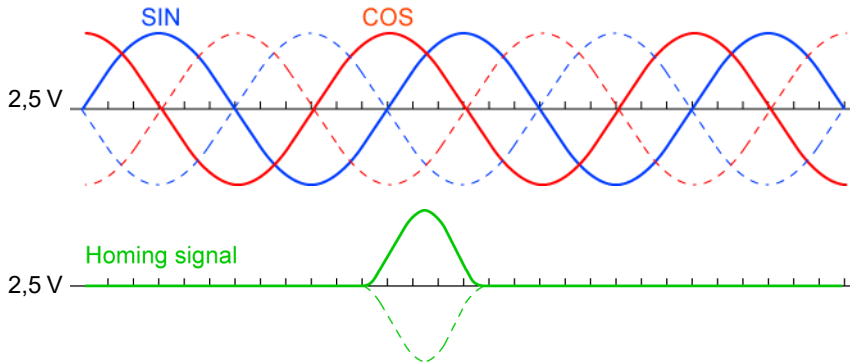

The encoders are temperature-compensated and deliver standardized output signals.

Technical data of the encoders

Data		I-encoder
		ERN 1380 ERN 1381
Sine-shaped voltage signals		
Signal level	V _{SS}	1 ±0.2
Offset	V	2.5 ±0.5
Resolution	Per./rotation	512 / 1024 / 2048
Symmetry deviation		≤0.065
Signal ratio		0.8 - 1.25
Phase angle	° el.	90 ±10
Homing signal		
Effective fraction	V	≥0.2
Resting value	V	≤1.7
Signal-to-noise ratio	V	0.04 - 0.68

Output circuit

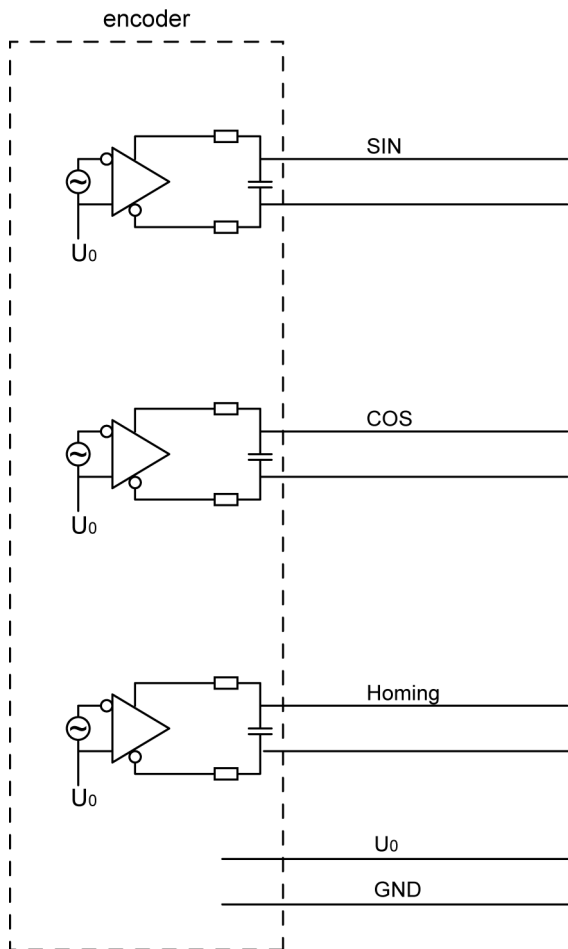

4.2.6 P- / Q-encoder

The following data are typical guidelines and can therefore deviate for the specific motor.

Encoder type	Technical description	Manufacturer / designation
P	<ul style="list-style-type: none"> • Absolute encoder (Siehe Seite 10.) • Singleturn (Siehe Seite 10.) • Digital (Siehe Seite 10.) 	Heidenhain ECI 1118 ECI 1319 ECI 119
	Resolution: 18 / 19 bit/revolution ²⁾	
	Measuring principle: inductive, permanent magnets (Siehe Seite 11.)	
	Protocol: EnDat 2.2 light	
	Electronic type plate (Siehe Seite 39.)	
Q	<ul style="list-style-type: none"> • Absolute encoder (Siehe Seite 10.) • Multiturn (Siehe Seite 10.) • Digital (Siehe Seite 10.) 	Heidenhain EQI 1130 EQI 1331
	Resolution: 18 / 19 bit/revolution ²⁾	
	Measuring principle: inductive (Siehe Seite 11.)	
	Protocol: EnDat 2.2 light	
	Electronic type plate (Siehe Seite 39.)	

2) depends on motor size

Output signal EnDat 2.2 light

The EnDat protocol transfers digital data between an encoder and the evaluation electronics according to the RS485 specification. The absolute positions are transferred synchronously to the cycle signal (CLOCK) specified by the evaluation electronics.

EnDat 2.2 has an expanded command set compared to EnDat 2.1. The command set of EnDat 2.1 is a component of EnDat 2.2.



EnDat 2.2 light means, that the encoder supports EnDat 2.2, which is used only with the commands of EnDat 2.1 from the AMK controller.

Output signal (SIN/COS track)

Signal sequence depicted for clockwise turning of the motor shaft with direction of view toward the A bearing side of the shaft.

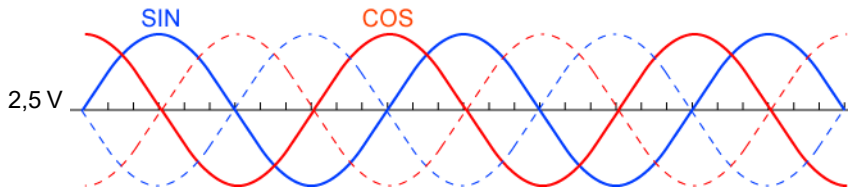

Technical data of the encoders

Data		P-encoder			Q-encoder	
		ECI 1118	ECI 1319	ECI 119	EQI 1130	EQI 1331
Voltage supply	VDC	5 ±5 %	4.75 - 10	5 ±5 %	5 ±5 %	4.75 - 10
Current consumption without load (5 V)	mA	120	80	135	145	90
Mechanically permitted speed	1/min	15000	15000	6000	12000	12000
Analog signals (SIN/COS)						
Analog resolution	Per./rotation	16	32	32	16	32
Signal level	V _{SS}	1 ±0.2			1 ±0.2	
Offset	V	2.5 ±0.5			2.5 ±0.5	
Absolute position values						
Signal characteristic		RS485			RS485	
Digital resolution	Pos./rotation	262144 (18 Bit)	524288 (19 Bit)	524288 (19 Bit)	262144 (18 Bit)	524288 (19 Bit)
Rotations		1			4096 (12 Bit)	

Output circuit

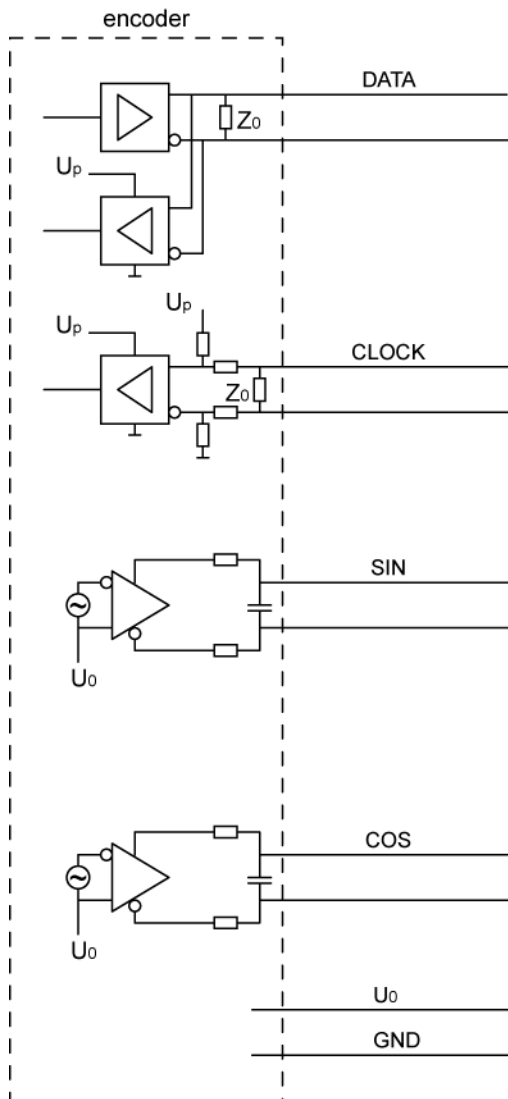

$Z_0 = 120 \Omega$

4.2.7 R-encoder (resolver)

The following data are typical guidelines and can therefore deviate for the specific motor.

Encoder type	Technical description	Manufacturer / designation
R	<ul style="list-style-type: none"> Absolute encoder (Siehe Seite 10.) Singleturn (Siehe Seite 10.) Analog (Siehe Seite 9.) 	Tyco V23401-D1001
	Resolution: 1 period/revolution	
	Measuring principle: resolver (Siehe Seite 13.)	

Output signal

Siehe 'Resolver' auf Seite 13.

Technical data of the encoder

Data		Resolver
		Bomatec Tyco V23401-D1001
Mechanically permitted speed	1/min	20000
Exciter signal		
Frequency	kHz	4 - 20
Primary voltage	V	2 - 10
Current consumption without load	mA	20 - 60
Transmission ratio		0.5 ±5 %
Input impedance	Ω	150 - 300
Output signals		
Signal form		Sine-shaped voltage signals
Number of pole pairs		1
Signal level	V _{SS}	1 - 1.8
Phase angle	° el.	90 ±10
Output impedance	Ω	150 - 300

4.2.8 S- / T-encoder

The following data are typical guidelines and can therefore deviate for the specific motor.

Encoder type	Technical description	Manufacturer / designation
S	<ul style="list-style-type: none"> • Absolute encoder (Siehe Seite 10.) • Singleturn (Siehe Seite 10.) • Digital (Siehe Seite 10.) • Analog (Siehe Seite 9.) 	Sick Stegmann SKS 36 SRS 50
	Digital resolution: 15 bit/revolution	
	Analog resolution: 128 / 1024 periods/revolution	
	Measuring principle: optical (Siehe Seite 11.)	
	Protocol: Hiperface	
	Electronic type plate (Siehe Seite 39.)	
T	<ul style="list-style-type: none"> • Absolute encoder (Siehe Seite 10.) • Multiturn (Siehe Seite 10.) • Digital (Siehe Seite 10.) • Analog (Siehe Seite 9.) 	Sick Stegmann SKM 36 SRM 50
	Digital resolution: 15 bit/revolution	
	Analog resolution: 128 / 1024 periods/revolution	
	Measuring principle: optical (Siehe Seite 11.)	
	Protocol: Hiperface	
	Electronic type plate (Siehe Seite 39.)	

Output signal Hiperface

The Hiperface encoder interface is a hybrid interface with an analog process data channel with SIN/COS track and a digital, bidirectional RS485 interface for serial transmission of the absolute position between an encoder and the evaluation electronics. The absolute value is created when the device is switched on and communicated to the drive controller through the RS485 interface.

Output signal (SIN/COS track)

Signal sequence depicted for clockwise turning of the motor shaft with direction of view toward the A bearing side of the shaft.

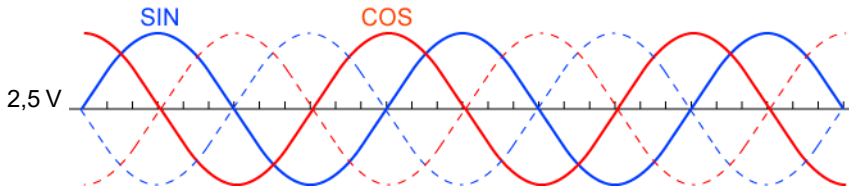

The encoders are temperature-compensated and deliver standardized output signals.

Technical data of the encoders

Data		S-encoder		T-encoder	
		SKS 36	SRS 50	SKM 36	SRM 50
Voltage supply	VDC	7 - 12	7 - 12	7 - 12	7 - 12
Current consumption without load (8 V)	mA	60	80	60	80
Mechanically permitted speed	1/min	12000	12000	12000	12000
Analog signals (SIN/COS)					
Analog resolution	Per./rotation	128	1024	128	1024
Signal level	V _{SS}	1 ± 0.2			
Offset	V	2.5 ± 0.5		2.5 ± 0.5	
Absolute position values					
Signal characteristic		RS485		RS485	
Digital resolution	Pos./rotation	4096 (12 Bit)	32768 (15 Bit)	4096 (12 Bit)	32768 (15 Bit)
Rotations		1		4096 (12 Bit)	

Note on startup

When switching on the power supply, or when doing a homing cycle, the encoder must not turn because the digital position is read twice and plausibility checked. If the difference between both read positions is out of the internal defined range, the diagnosis message info 1 = 7 is issued.

4.2.9 U- / V-encoder

The following data are typical guidelines and can therefore deviate for the specific motor.

Encoder type	Technical description	Manufacturer / designation
U	<ul style="list-style-type: none"> • Absolute encoder (Siehe Seite 10.) • Singleturn (Siehe Seite 10.) • Digital (Siehe Seite 10.) • Analog (Siehe Seite 9.) 	Sick Stegmann SEK 37
	Digital resolution: 9 bit/revolution	
	Analog resolution: 16 periods/revolution	
	Measuring principle: capacitive (Siehe Seite 14.)	
	Protocol: Hiperface	
	Electronic type plate (Siehe Seite 39.)	
V	<ul style="list-style-type: none"> • Absolute encoder (Siehe Seite 10.) • Multiturn (Siehe Seite 10.) • Digital (Siehe Seite 10.) • Analog (Siehe Seite 9.) 	Sick Stegmann SEL 37
	Digital resolution: 9 bit/revolution	
	Analog resolution: 16 periods/revolution	
	Measuring principle: capacitive (Siehe Seite 14.)	
	Protocol: Hiperface	
	Electronic type plate (Siehe Seite 39.)	

Principle

The transmitter circuit board has a coarsely resolving disk track with three pulses per rotation and a finely resolving track with 16 pulses per rotation. The receiver circuit board situated opposite has two conductive tracks with which the coarse and fine pulses are recorded respectively. The pulses are generated or modulated through a toothed rotor, which changes the dielectric between the sender circuit board and the receiver circuit board through its rotation.

The multiturn characteristic of the V encoder is achieved through a mechanical gearbox as well as magnets and Hall sensors.

Output signal Hiperface

The Hiperface encoder interface is a hybrid interface with an analog process data channel with SIN/COS track and a digital, bidirectional RS485 interface for serial transmission of the absolute position between an encoder and the evaluation electronics. The absolute value is created when the device is switched on and communicated to the drive controller through the RS485 interface.

Output signal (SIN/COS track)

Signal sequence depicted for clockwise turning of the motor shaft with direction of view toward the A bearing side of the shaft.

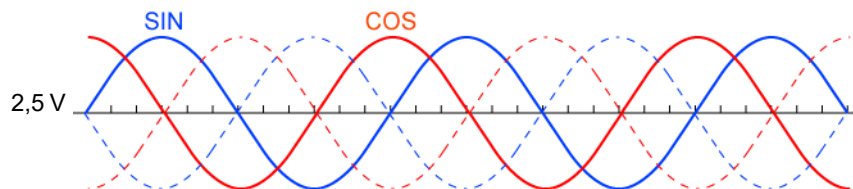

Technical data of the encoders

Data		U-encoder	V-encoder
		SEK 37	SEL 37
Voltage supply	VDC	7 - 12	7 - 12
Current consumption without load (8 V)	mA	50	50
Mechanically permitted speed	1/min	12000	12000
Analog signals (SIN/COS)			
Analog resolution	Per./rotation	16	16
Signal level	V _{SS}	1 ±0.2	1 ±0.2
Offset	V	2.5 ±0.5	2.5 ±0.5
Absolute position values			
Signal characteristic		RS485	
Digital resolution	Pos./rotation	512 (9 Bit)	512 (9 Bit)
Rotations		1	4096 (12 Bit)

Note on startup

When switching on the power supply, or when doing a homing cycle, the encoder must not turn because the digital position is read twice and plausibility checked. If the difference between both read positions is out of the internal defined range, the diagnosis message info 1 = 7 is issued.

4.2.10 Y-encoder

The following data are typical guidelines and can therefore deviate for the specific motor.

Encoder type	Technical description	Manufacturer / designation
Y	<ul style="list-style-type: none"> • Absolute encoder (Siehe Seite 10.) • Singleturn (Siehe Seite 10.) • Multiturn (Siehe Seite 10.) • Digital (Siehe Seite 10.) 	Sick Stegmann singleturn: EKS 36 EFS 50
	Resolution: 17 / 20 / 23 bit/revolution	multiturn: EKM 36 EFM 50
	Measuring principle: optical (Siehe Seite 11.)	
	Protocol: Hiperface DSL	
	Electronic type plate (Siehe Seite 39.)	

Output signal

The Hiperface DSL protocol transmits digital data between an encoder and the drive controller by modulating the data into the supply line of the encoder. The absolute positions are send serial and cyclic synchronous from the encoder triggered by the trigger signal of the drive controller.

Technical data of the encoders

Data		Singleturn encoder			Multiturn encoder		
		EKS 36	EFS 50		EKM 36	EFM 50	
Voltage supply	VDC	9 ±15 %		9 ±15 %	9 ±15 %		9 ±15 %
Current consumption without load (8 V)	mA	60		60	60		60
Mechanically permitted speed	1/min	12000		12000	9000		9000
Absolute position values							
Signal characteristic		RS485			RS485		
Resolution	Pos./U	131072 (17 Bit)	1048576 (20 Bit)	8388608 (23 Bit)	131072 (17 Bit)	1048576 (20 Bit)	8388608 (23 Bit)
Rotations		1		1	4096 (12 Bit)		4096 (12 Bit)

Output circuit, encoder

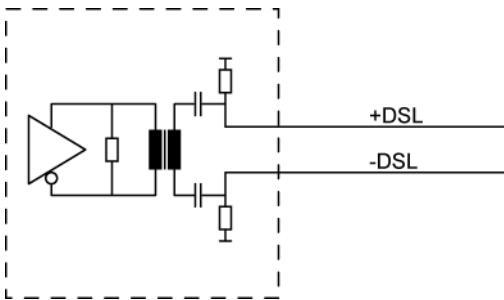

4.3 Encoder type in the motor designation

The type of encoder that is built into the AMK motors can be taken from the type designation of the motor.

Examples:

DT 5 - 3 - 10 - R B O - 5000
 |
 Resolver

iDT 5 - 5 - 10 - E B O - 4900
 |
 E-encoder

SKT 7 - 17 - 20 - Q O O - 3500
 |
 Q-encoder

SEZ 3 - 0.5 - 5 - 70 - K Q O O - 8400
 |
 Q-encoder

5 Encoder interfaces in AMK converters

The following sections describe the encoder interfaces of the various controllers in the AMK converters.

The chapter 'Controller support' gives an overview of which encoders can be used with the respective controllers. (Siehe 'Controller support' auf Seite 16.)

You can find further information on the drive controllers in the device descriptions:

- Decentralized drive technology iC / iX / iDT5 (Part no. 203445)
- Controller cards KW-R24(-R) / -R25 / -R26 / -R27 (Part no. 204918)
- Controller cards KW-R06 / -R16 / -R07 / -R17 (Part no. 202744)
- Controller card KW-R05 (Part no. 202184)
- Controller cards KW-R03 / -R03P / -R04 (Part no. 29881)

5.1 [X130] resolver / Hall encoder

Supported hardware: KW-R06 / KW-R07 / KW-R24-R

Description

This connection supports following encoder types: R and H

Technical data

- Maximum encoder line length: 100 m

Design

Type	Poles	Class
D-SUB	9	Socket

Assignment

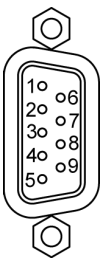
[X130]	Connection	Signal
front view, device side 	1	-
	2	-
	3	+SIN
	4	-SIN
	5	+COS
	6	-COS
	7	+UREF ²⁾
	8	-UREF / GND ^{1) 2)}
	9	-5 VDC ¹⁾

1) Supply voltage for Hall encoder

2) Excitation voltage for Resolver

Connection

Cable	4 x 2 x 0.25 mm ² twisted pair + 4 x 0.5 mm ² shielded
Shield connection	Shield on both sides
Cable assembly	D-SUB connector 9-pin with metalized housing
Note	The shield of the cable has to be grounded by the screw connection in the plug housing on the motor side. The shield mesh is everted over the terminal insert. After screwing together, the shield is placed over the contact spring and the plug housing on the mass.

Controller input circuit

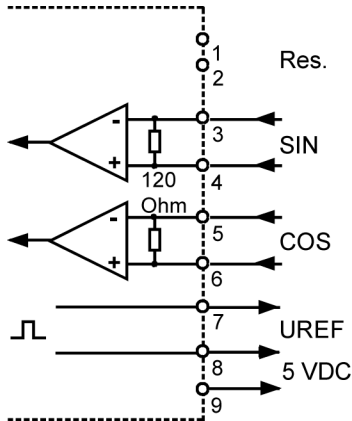

Requirements to the encoder

Encoder evaluation according ID32953		R-encoder	H-encoder
Data	Units	Resolver	Hall encoder
Excitation signal			
Primary voltage	VDC	6 ±8 %	5 ±5 %
Input current without load	mA	max. 75	max. 350
Frequency [kHz]	kHz	8	-
Output signals			
Transmission ratio		0.5 ±5 %	-
Number of pole pairs 1)		1	1
Output voltage	V _{SS}	1 - 1.8	0.6 - 1.1

1) Resolvers / Hall encoders with one pole pair are exclusively permitted!

Encoder signal

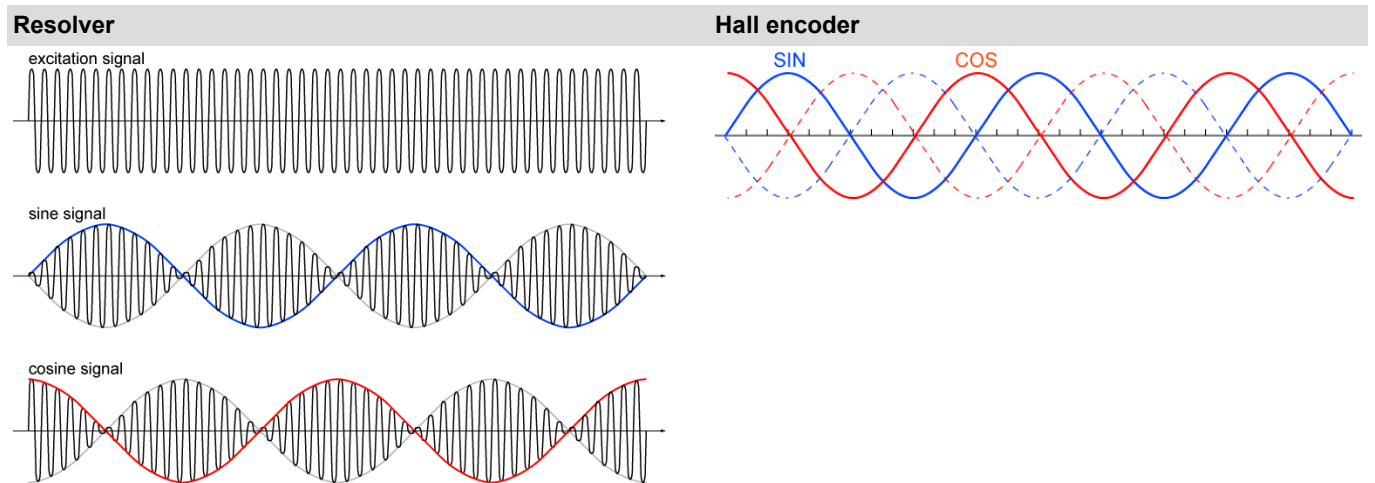

Encoder signal evaluation

In ID32953 'Encoder type' is defined how to evaluate the incoming encoder signals.

5.2 [X131] sine encoder

Supported hardware: KW-R06 / KW-R16 / KW-R07 / KW-R17 / KW-R25 / KW-R26 / KW-R27 /

Description

This interface supports the following encoder types:
E, F, I, P, Q, S, T, U, V, Y (Y only KW-R26 and KW-R27)

Siehe 'Controller support' auf Seite 16.

Technical data

- The maximum input frequency is 200 kHz
- Input signals according to RS485 specification
- Encoder line length:

Encoder designation	ERN 1380 ERN 1381	ECN 1113 ECN 1313 EQN 1125 EQN1325	ECN 113^{*)}	ECI 119 ECI 1118 ECI 1319 EQI 1130 EQI 1331	SKS 36 SRS 50 SKM 36 SRM 50	SEK 37 SEL 37	EKS 36 EFS 50 EKM 36 EFM 50
AMK Encoder designation	I	E / F		P / Q	S / T	U / V	Y
max. Encoder line length [m]	100	100 KW-R25: 25 m	25	100 KW-R25: 25 m	100	100	100 at AWG 22 30 at AWG 26

- *) The encoder ECN113 does not have an extended voltage range and can therefore only be employed with line lengths up to a maximum of 25 m. The encoder is built into the following motors:
- DT7-28-20-EOO-2600-B5 (part no.: A1216AD)
 - SKT7-55-20-EBW-5200-DB-B9 (part no.: A1706ED)
 - SKT7-55-20-EOW-5200-DB-B9 (part no.: A1706ED)
 - SKWS13-150-6-EOW-800-B5 (part no.: A1024AC)
 - SKWS13-150-6-EOW-800-B5*AT (part no.: D611AC)



The above mentioned line lengths are valid only with the specified voltage ranges and the cable cross-sections recommended by AMKmotion.

Design

Type	Poles	Class
D-SUB	15	Socket

Assignment

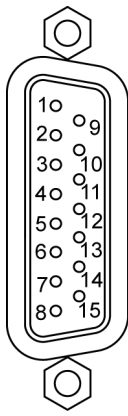
[X131]	Connection	I-encoder	E- / F-encoder	P- / Q-encoder	S- / T-, U- / V-encoder	Y-encoder
front view, device side 	1	-REF	-	-	-	-
	2	+REF	-	-	-	-
	3	-COS	-COS	-	-COS	-
	4	+COS	+COS	-	+COS	-
	5	-SIN	-SIN	-	-SIN	-
	6	+SIN	+SIN	-	+SIN	-
	7	5 VDC ¹⁾	5 VDC ¹⁾	5 VDC ¹⁾	-	-
	8	GND	GND	GND	GND	-
	9	-	-EN_DAT	-EN_DAT	-RS485	-
	10	-	+EN_DAT	+EN_DAT	+RS485	-
	11	-	-EN_CLK	-EN_CLK	-	-
	12	-	+EN_CLK	+EN_CLK	-	-
	13	-	5 VDC ¹⁾	5 VDC ¹⁾	-	-
	14	GND	GND	GND	GND	-DSL ³⁾
	15	-	-	-	9 VDC ²⁾³⁾	+DSL ³⁾

- 1) 5 VDC ±5 % max. 350 mA
- 2) KW-R06 / KW-R16 / KW-R07 / KW-R17 /
9 VDC ±15 % at load; max. 400 mA, 12 VDC ±20 % in idle
- 3) KW-R26 / KW-R27 /
9 VDC ±15 % at load, max. 400 mA, short-circuit-protected

Connection

	E- / F- / I- / P- / Q- / S- / T- / U- / V-encoder	Y-encoder
Cable	E- / F- / P- / Q- encoder: 4 x 2 x 0.25 mm ² twisted pair, + 4 x 0.5 mm ² shielded I- / S- / T- / U- / V-encoder: 4 x 2 x 0,5 mm ² twisted pair shielded	Hybrid cable DSL: twisted pair, shielded 4 x 1,5 mm ² +(2 x 0,75 mm ²)+(2 x AWG22 or AWG26) 4 x 0,5 mm ² +(2 x 0,75 mm ²)+(2 x AWG22 or AWG26) z. B. HELUKABEL and Tecni
Shield connection	Shielded on both sides	Shielded on both sides
Cable assembly	D-SUB connector 15-pin with metallized casing	
Note	The shield of the cable has to be grounded by the screw connection in the plug housing on the motor side. The shield mesh is everted over the terminal insert. After screwing together, the shield is placed over the contact spring and the plug housing on the mass.	

Controller input circuit

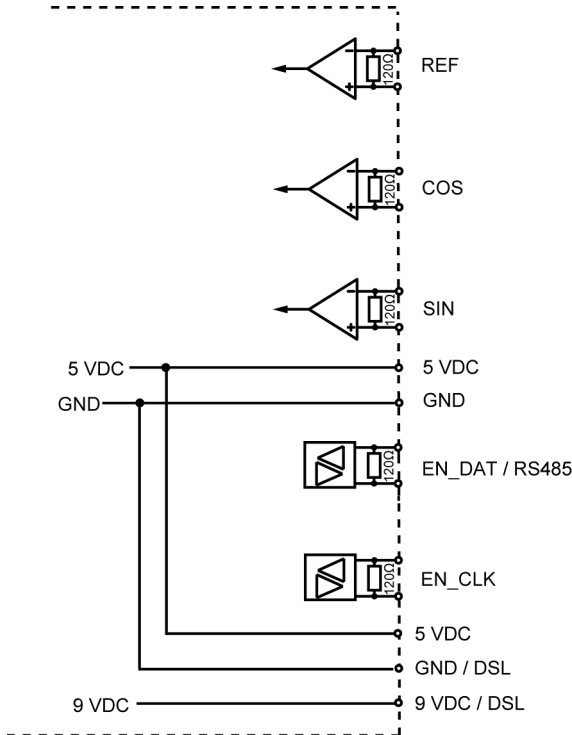

Requirements for the encoder

Encoder evaluation in accordance with ID32953		I-encoder	E- / F-encoder	S- / T-, U- / V-encoder	P- / Q-encoder	Y-encoder
Data		Sine encoder	EnDat 2.1	Hiperface	EnDat 2.2 light (digital) ³⁾	Hiperface DSL
Voltage supply to the encoder						
Input voltage	VDC	5 ±5% ¹⁾	5 ±5% ¹⁾	9 ±15% ²⁾	5 ±5% ¹⁾	9 VDC ±15% ⁴⁾
Output signals of the analog tracks						
Output voltage	V _{SS}	0.6 - 1.1			-	-
Offset	V	2.5 ±0.5			-	-
Output signal of the homing track						
Resting value	mV	200	-	-	-	-
Signal width	° el.	90 ... 270	-	-	-	-

- 1) 5 VDC ±5 % max. 350 mA
- 2) 9 VDC ±15 % at load; max. 400 mA, 12 VDC ±20 % in idle
- 3) EnDat 2.2 light means, that the encoder supports EnDat 2.2, which is used only with the commands of EnDat 2.1 from the AMK controller.
- 4) 9 VDC ±15 % at load, max. 400 mA, short-circuit-proofed

Encoder signal

Analog tracks

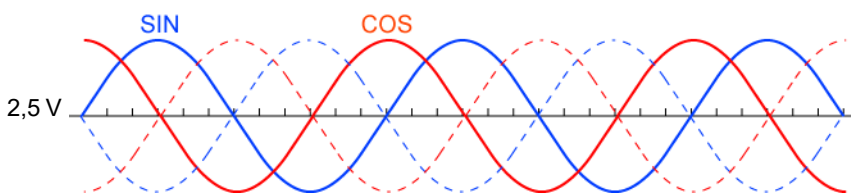

Homing signal

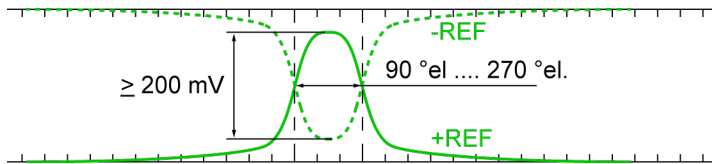

To receive a unique signal, the homing signals (+REF and -REF) must overlap by at least 200 mV. The overlap range must be at least 90 °el. and maximum 270 °el. long.

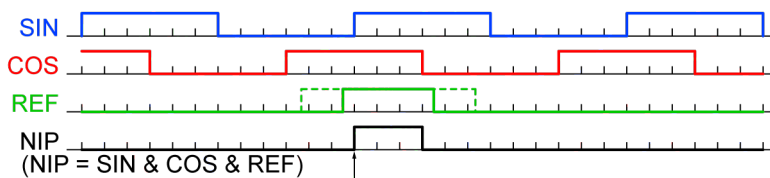
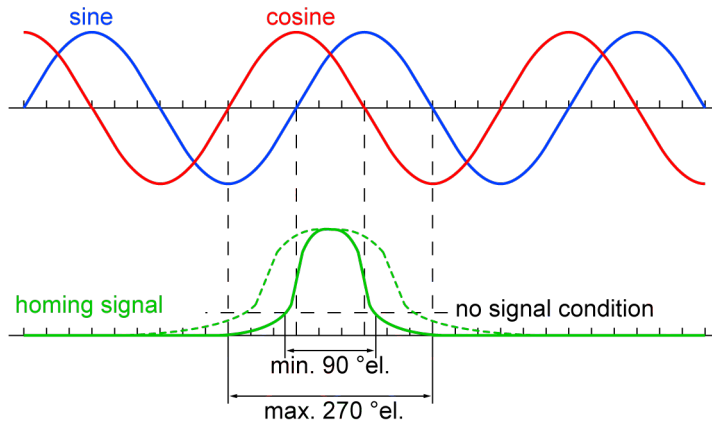

The zero pulse NIP is determined in the controller. A logic AND link of SIN, COS and REF results in the NIP signal. The positive edge (for right-turning motor) is evaluated for exact determination of the zero pulse.

Encoder signal evaluation

In ID32953 'Encoder type' is defined how to evaluate the incoming encoder signals.

5.3 [X05] Encoder connection

Supported hardware: iX / iC /

Description

This terminal supports the following encoder types: E, F, H, I, P, Q, S, T, U, V

Technical data

- Maximum input frequency is 200 kHz
- Input signals matches the requirements of RS485 specification
- Maximum encoder line length: 20 m

Design

Type	Pole	Sort	Manufacturer	Designation
-	6	Socket	ITT Cannon	Red socket insert for connector CM3 [X05.1]
-	6	Socket	ITT Cannon	Blue socket insert for connector CM3 [X05.2]

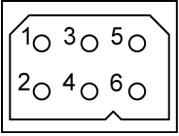
[X05.1] CM3 connector	Connection	I- / H-encoder	E- / F-encoder	P- / Q-encoder ³⁾	S- / T-, U- / V-encoder
Front view, device side 	1	+REF ⁴⁾	+EN_DAT	+EN_DAT	-
	2	-REF ⁴⁾	-EN_DAT	-EN_DAT	-
	3	GND	GND	GND	-
	4	5 VDC ¹⁾	5 VDC ¹⁾	5 VDC ¹⁾	-
	5	-	-EN_Clk	-EN_Clk	-RS485
	6	-	+EN_Clk	+EN_Clk	+RS485

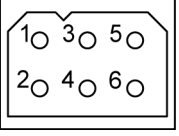
[X5.2] CM3 connector	Connection	I- / H-encoder	E- / F-encoder	P- / Q-encoder ³⁾	S- / T-, U- / V-encoder
Front view, device side 	1	GND	GND	GND	GND
	2	-	-	-	8 VDC ²⁾
	3	+SIN	+SIN	-	+SIN
	4	-SIN	-SIN	-	-SIN
	5	+COS	+COS	-	+COS
	6	-COS	-COS	-	-COS

1) 5 VDC ±5 %, max. 350 mA

2) 8 VDC ±5 % under load, max. 150 mA; 9 VDC ±20 % when idle

3) P- and Q-encoder with analog tracks can be used and parameterized in ID32953 as E- and F-encoder

4) Only for I-encoder, not for H-encoder

Connection

Connector plug	CM3
Mating connector	2 x 6-pole, pin
Cable	4 x (2 x 0.25mm ²) + 4 x 0.5 mm ² / AWG 24 + AWG 20, shielded
Shield connection	Apply on both sides
Tightening torque	-
Accessories	Prefabricated cable

Controller input circuit

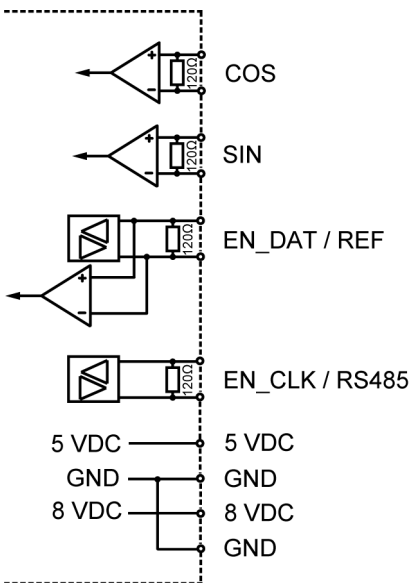

Requirements for the encoder

Encoder evaluation in accordance with ID32953		I- / H-encoder	E- / F-encoder	S- / T-, U- / V-encoder	P- / Q-encoder
Data		Sine encoder	EnDat 2.1	Hiperface	EnDat 2.2 light (digital) ³⁾
Voltage supply to the encoder					
Input voltage	VDC	5 ±5 % ¹⁾	5 ±5 % ¹⁾	8 ±5 % ²⁾	5 ±5% ¹⁾
Output signals of the analog tracks					
Output voltage	V _{SS}	0.6 - 1.1			-
Offset	V	2.5 ± 0.5			-
Output signal of the homing track					
Resting value		200 mV	-	-	-
Signal width		90 ... 270° el.	-	-	-

- 1) 5 VDC ±5 % max. 350 mA
- 2) 8 VDC ±5 % with load, max. 150 mA; 9 VDC ±20 % at idle
- 3) EnDat 2.2 light means, that the encoder supports EnDat 2.2, which is used only with the commands of EnDat 2.1 from the AMK controller.

Encoder signal

Analog tracks

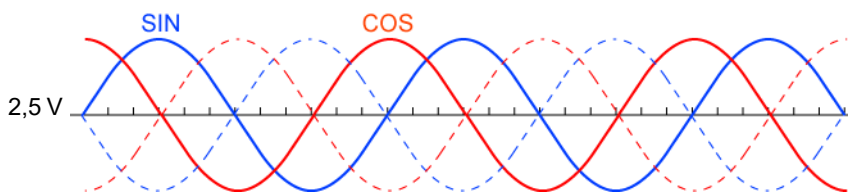

Homing signal

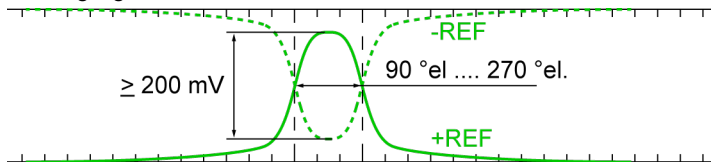

To receive a unique signal, the homing signals (+REF and -REF) must overlap by at least 200 mV. The overlap range must be at least 90 °el. and maximum 270 °el. long.

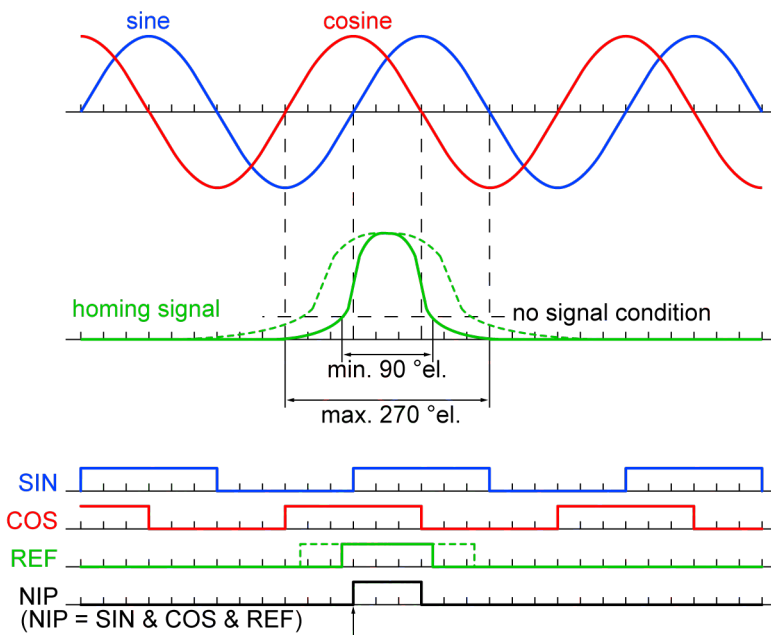

The zero pulse NIP is determined in the controller. A logic AND link of SIN, COS and REF results in the NIP signal. The positive edge (for right-turning motor) is evaluated for exact determination of the zero pulse.

Encoder signal evaluation

In ID32953 'Encoder type' is defined how to evaluate the incoming encoder signals.

6 Notes on startup for encoders

6.1 Electronic type plate (encoder with internal memory)

In encoders with an internal memory, AMK motor and encoder parameters are stored at the factory, the so-called 'electronic type plate'. This information is read by the controller during system booting or with a service command.

See document Function description 'Control loop setting', subtopic current controller.

6.2 Parameterization

- The encoder type and the related encoder signal evaluation are established in the parameter ID32953 'Encoder type'. The signal periods of the encoder are interpolated in the evaluation and depicted on the resolution set in ID116 'Resolution motor encoder'.
- For encoders with electronic type plate, the parameter values are stored at the factory and do not have to be input. For encoders without electronic type plate, the values must be parameterized by the user. (Manual parameterization of the IDs or transfer of the parameters from the motor database in AIPEX)
- For parameter changes that affect the encoder and motor parameters, a system booting via power supply ON/OFF is always recommended.
- The maximum permitted mechanical speed of the encoder can considerably exceed the permitted motor speed.
- Observe the maximum permitted input frequency at the encoder connection of the converter.

Glossary

A

AIPEX

AMK startup and parameterizing software (PC software): Programming, parameterization, configuration, diagnosis, oscilloscope, status information

ASCII

American Standard Code for Information Interchange

AT

Drive telegram from slave to master

A-encoder

Inductive magnetoresistor sensor with sine and cosine track and homing signal (zero pulse)

AWG

American Wire Gauge (Coding of wire diameter)

B

BIN

Binary (digital)

B-encoder

Hall sensor in iDT4 motors, singleturn

C

CMD

Commanding

CRC

Cyclic redundancy check (Checksum)

C-encoder

Hall sensor in iDT4 motors, multiturn

D

DZR

Speed control

DRIVE

Drive-specific parameter (Value is valid inside only one parameter set)

DI

Digital input

Default

Factory setting

DO

Digital output

DEZ

Decimal

E

EF

Power output stage enable

EF2

Power output stage enable

E-encoder

Absolute encoder, singleturn, EnDAT 2.1 with additional sine and cosine track

EMV

Electromagnetic compatibility

EMC

Electromagnetic compatibility

EnDat 2.1

Motor encoder interface protocol of the company Heidenhain

EnDat 2.2

Motor encoder interface protocol of the company Heidenhain

EtherCAT

Real-time Ethernet bus

F

FTP

File transfer protocol

FSoE

Fail-Safe over EtherCAT

Formal parameter

Formal parameters don't have remanent values in parameter handling

F-encoder

Absolute encoder, multiturn, EnDAT 2.1 with additional sine and cosine track

Firmware

System software, loaded by AMK

FIPO

Fine interpolator

FORMAL

Formal parameter

G

GLOBAL

Global parameter; valid for all parameter sets

H**HEX**

Hexadecimal, 0x...

Hiperface

Motor encoder interface protocol of the company Sick Stegmann

Hiperface DSL

Motor encoder interface protocol of the company Sick Stegmann

H-encoder

Encoder with Hall sensors (Contains one sine and cosine track per rotation or per pair of poles on linear measuring systems)

I**I**

Input

I/O

Input / output

i²t

Integral of the squared current over time

ID

Parameter identification numbers acc. to SERCOS Standard

iDT

AMKASMART Servo motors with integrated inverter

I-encoder

Incremental encoder, optical encoder with sine and cosine track and zero pulse

IGBT

Power electronic component, e. g. transistor

Instance

Parameters, depending on the fieldbus, are instanced. For each bus, different values can be parameterized (bus depending participant address, transmission rate etc.). Field bus interfaces and slots where field bus option cards can be installed are allocated to instances (see product documentation)

IPO

Interpolator

iX

AMKASMART decentralized inverter

iC

AMKASMART decentralized inverter with power supply

K**KTY**

Type of a temperature sensor

KW-Rxx

AMKASYN controller card for installation into compact inverter

KP

Proportional gain (speed control, PID controller)

KW

AMKASYN compact inverter

Kv

Position loop factor

L**LR**

Position control

LSB

Least Significant Bit

M**MST**

Master synchronization telegram

MSB

Most Significant Bit

MDT

Master Data Telegram from master to slave

Modulo

Modulo processing of position setpoint and actual values

M(N)

Nominal torque

MPU

Measuring steps of the encoder per revolution (digital value for P- and Q-encoders)

N**NIP**

Zero pulse of encoder

NK

Cam switch

O**OSC**

Oscilloscope

P**Parameter**

Identification number acc. to SERCOS standard

P-encoder

Absolute encoder singleturn, EnDAT 2.2 light

PGT

Periphery basic clock Fetch cycle in the basic device to which the drive controller is synchronized (The cycle time is according to ID2)

PTC

PTC resistor

PWM

Pulse width modulation

PKD_XXXXXX_abcdefgh

Product documentation; xxxxxx - AMK part no. , abcdefgh - name

Q

QBR

Acknowledgment motor holding brake

Q-encoder

Absolute encoder multiturn, EnDAT 2.2 light

QRF

Acknowledgment controller enable; the drive is controlled in the activated operation mode

QUE

Acknowledgment DC bus on; shows that DC bus is loaded

R

Resolver

Absolute angle encoder singleturn (1 sine and cosine track per rotation)

R-encoder

Absolute angle encoder singleturn (1 sine and cosine track per rotation)

RF

Command 'Controller enable'; the drive is energized and will be controlled depending on the selected operation mode. Controller enable can only be set if the device is error-free (SBM = TRUE) and acknowledgement DC bus on is set (QUE = TRUE). Acknowledgment controller enable (QRF) is set.

S

SWC

Software commutation

STO

Safe torque off (Safety function acc. to DIN EN 61800-5-2)

SS1

Safe Stop 1 (Safety function acc. to DIN EN 61800-5-2)

SoE

Servodrive Profile (SERCOS) over EtherCAT (Acc. to IEC 61800-7-300)

SAK

Following distance error compensation

Sensorless

Operation mode without encoder

S-encoder

Absolute encoder, singleturn, RS485 Hiperface with sine and cosine track

SEEP

Device-internal memory, serial EEPROM

SBM

System ready message; shows that the device is error-free In case of error. SBM will be reset

SERCOS

Standardized digital interface for communication between controller and field bus participants.

T

Td

Differentiating time in speed control (PID controller)

Tn

Integral-action time in speed control (PID controller)

TR

Rotor time constant

T-encoder

Absolute encoder, multiturn, RS485 Hiperface with sine and cosine track

U

U/f

Voltage / frequency control (open loop)

V/f

Voltage / frequency control (open loop)

U-encoder

Absolute encoder, singleturn, RS485 Hiperface with sine and cosine track

UE

Command 'DC bus on' control signal to load the DC bus e.g. in KE. DC bus on can only be set if the device is error-free (SBM = TRUE). After the DC bus is loaded, the acknowledgement message QUE is set.

UPS

Uninterruptible power supply

V

V-encoder

Absolute encoder, multiturn, RS485 Hiperface with sine and cosine track

Y**Y-encoder**

Absolute encoder, singleturn or multiturn, RS485 Hiperface DSL

Your opinion is important!

With our documentation we want to offer you the highest quality support in handling the AMKmotion products.

That is why we are now working on optimizing our documentation.

Your comments or suggestions are always of interest to us.

We would be grateful if you take a bit of time and answer our questions. Please return a copy of this page to us.



e-mail: Documentation@amk-motion.com

or

fax no.: +49 7021/50 05-199

Thank you for your assistance.

Your AMKmotion documentation team

1. How would you rate the layout of our AMKmotion documentation?

(1) very good (2) good (3) satisfactory (4) less than satisfactory (5) poor

2. Is the content structured well?

(1) very good (2) good (3) moderate (4) hardly (5) not at all

3. How easy is it to understand the documentation?

(1) very easy (2) easy (3) moderately easy (4) difficult (5) extremely difficult

4. Did you miss any topics in the documentation?

(1) no (2) if yes, which ones:

5. How would you rate the overall service at AMKmotion?

(1) very good (2) good (3) satisfactory (4) less than satisfactory (5) poor

AMKmotion GmbH + Co KG

Phone : +49 7021/50 05-0, fax: +49 7021/50 05-199

E-Mail: info@amk-motion.com

Homepage: www.amk-motion.com