



SPINDASYN

Device description

SEZ - Spindasyn electric cylinder

Version: 2023/26

Part no.: 204540

Translation of the "Original Dokumentation"

AMK*motion*

MEMBER OF THE ARBURG FAMILY

Imprint**Name:** PDK_204540_Motoren_SEZ**Version:**

Version	Change	Initials
2023/26	<ul style="list-style-type: none">• Correction of the power connection PAC Drive3 - Cable is 4x1,5 mm²• AMKmotion Design	LeS

Previous version: 2020/40**Product version:**

Product Part no.	Firmware Version (Part no.)	Hardware Version (Part no.)
SEZ 3	-	
SEZ 4		

Copyright notice:

© AMKmotion GmbH + Co KG

Any transfer or reproduction of this document, as well as utilisation or communication of its contents, requires express consent. Offenders are liable for the payment of damages. All rights are reserved in the event of the grant of a patent or the registration of a utility model or design.

Reservation:

We reserve the right to modify the content of the documentation as well as the delivery options for the product.

Publisher:

AMKmotion GmbH + Co KG
Gaußstraße 37-39
73230 Kirchheim unter Teck
Germany

Phone +49 7021 50 05-0

Fax +49 7021 50 05-176

E-mail: info@amk-motion.com

Registration court: AG Stuttgart, HRA 230681, Kirchheim unter Teck,

Tax Id no.: DE 145 912 804

Complementary: AMKmotion Verwaltungsgesellschaft mbH, HRB 774646

Service:

Phone +49 7021 50 05-190, Fax -193

For fast and reliable troubleshooting, you can help us by informing our Customer Service about the following:

- Type plate data for each unit
- Software version
- Device configuration and application
- Type of fault/problem and suspected cause
- Diagnostic messages (error messages)

E-mail service@amk-motion.com**Internet address:**www.amk-motion.com

Content

Imprint	2
1 About this documentation	6
1.1 Structure of this document	6
1.2 Keeping this document	6
1.3 Target group	6
1.4 Purpose	7
1.5 Display conventions	7
1.6 Appendant documents	7
2 For your safety	8
2.1 Basic notes for your safety	8
2.2 Safety rules for handling electrical systems	8
2.3 Presenting safety messages	8
2.4 Class of hazard	9
2.5 Safety alert symbols used	9
2.6 Intended use	9
2.7 Requirements for the personnel and their qualification	10
2.8 CE mark	10
2.9 Warranty	10
3 Product overview	11
3.1 Product views	11
3.2 Variants of connections	12
3.3 Type code	13
3.4 Type plate	14
3.5 SEZ 3	16
3.5.1 Dimensional drawings	16
3.5.2 Technical data	17
3.6 SEZ 4	18
3.6.1 Dimensional drawings	18
3.6.2 Technical data	19
3.7 Screw nut	20
3.7.1 Dimensional drawings	20
3.7.2 Lead accuracy	20
3.8 Scope of delivery	21
4 Projecting	22
4.1 Motor holding brake	22
4.2 Balance quality grade	22
4.3 Overview of motor encoders	23
5 Transport and storage	26
5.1 Transport	26
5.2 Storage	26
6 Assembly	27
6.1 For your safety	27
6.2 Avoiding material damage	27
6.3 Prerequisites and preparations	28
6.4 Tightening torques	29
6.5 Pushing and pulling drive elements on and off	29
6.6 Initial lubrication of the screw nut	29
6.7 Convection-cooled motors	30
7 Electrical connections	31
7.1 EMC-compliant connections	31
7.2 Phase sequence	31

7.3 Connection diameters	31
7.4 Encoder connection	31
7.4.1 Encoder plug M23	31
7.4.1.1 Encoder plug M23 - Siemens compliant	34
7.4.1.2 Encoder plug M23 - PacDrive3 compliant	36
7.4.2 Encoder plug CM3	38
7.5 Power connection	39
7.5.1 For your safety	39
7.5.2 Avoiding material damage	40
7.5.3 Power plug round	41
7.5.3.1 Power plug round - Siemens compliant	42
7.5.3.2 Power plug round - PacDrive3 compliant	44
7.5.4 Power plug CM3	45
7.6 Hybrid connection	46
7.6.1 For your safety	46
7.6.2 Hybrid connector M15	47
7.7 Handling of the CM3-plug (ITT-Cannon)	49
8 Startup	51
8.1 For your safety	51
8.2 Avoiding material damage	53
8.3 Check list for preparing the startup	54
8.4 Switch-on	54
9 Operation	55
9.1 For your safety	55
9.2 Avoiding material damage	57
9.3 Machine downtimes	57
10 Diagnostics	58
11 Maintenance and repair	60
11.1 For Your safety	60
11.2 Avoiding material damage	62
11.3 Screw nut	62
11.3.1 Dismounting	62
11.3.2 Re-lubrication	62
11.4 Exchanging an absolute encoder	63
11.5 Maintenance intervals	63
11.6 Cleaning	64
12 Decommissioning and disposal	65
12.1 For your safety	65
12.2 Preparing disassembly	65
12.3 Disposing of the materials	65
13 Technical data	66
13.1 General technical data	66
13.2 Motor data	67
14 Accessories	68
14.1 Encoder connection M23	68
14.1.1 Encoder plug set	68
14.1.2 Encoder cable with M23-plug configured	68
14.2 Encoder cable with CM3 plug configured	69
14.3 Power connection M23	69
14.3.1 Power plug set	69
14.3.2 Power Cable with power plug configured	69
14.4 Power cable with CM3-plug configured	70
14.5 Hybrid cable configured	70
15 Certificates	71

Glossary	72
Your opinion is important!	74

1 About this documentation

1.1 Structure of this document

Topic	Chapter	Kapitelnummer
Validity, use and propose of the documentation	Imprint	-
	About this document	1
Safety	For Your safety	2
Information for planning and projecting personnel	Product overview	3
	Projecting	4
	Technical data	13
	Accessories	14
Practice information for startup, operating or maintenance personnel	Transport and storage	5
	Assembly	6
	Electrical connections	7
	Startup	8
	Operation	9
	Diagnostics	10
	Maintenance and repair	11
	Decommissioning and disposal	12
Reference to Certificates e. g. CSA, CE or TÜV	Certificates	15
Abbreviations and explanation of terms	Glossary	-

1.2 Keeping this document

This document must permanently be available and readable at the place where the product is in use. If the product is used at another place or changed the owner, the document must be passed on.

1.3 Target group

Any person that is qualified and intends to work with this product must read, understand and follow this document:

- Transportation and storage
- Unpacking and installation
- Projecting
- Connection
- Parameterization
- Startup
- Testing and maintenance
- Service and repair
- Decommissioning and disposal

1.4 Purpose

This document is addressed to any person who handles the product. It gives information about the following topics:

- Safety messages which are absolutely necessary to take care of during handling the product
- Product identification
- Projecting, planning and dimensioning of the application
- Environmental conditions for storage, transportation and operation
- Assembly
- Electrical connections
- Startup and operation
- Maintenance
- Repair
- Replacement
- Diagnosis
- Decommissioning and disposal
- Technical data
- Conformity with standards

1.5 Display conventions

Display	Meaning
	This symbol points to parts of the text to which particular attention should be paid!
0x	0x followed by a hexadecimal number, e. g. 0x500A
'Names'	Names are represented with apostrophes e. g. parameters, variables, etc.
See 'chapter name' on page x	Executable cross-reference in electronic output media

1.6 Appendant documents

Device descriptions

AMK part-no.	Titel
27859	Motor encoders
-	Motor data sheets

Functional documentations

AMK part-no.	Titel
204979	Software description AIPEX PRO V3 (PC software for startup and parameterization)

2 For your safety

2.1 Basic notes for your safety

- At electrical drive systems, hazards are present in principle that can result in death or fatal injuries:
 - Electrical hazard (e. g. electric shock due to touch on electrical connections)
 - Mechanical hazard (e. g. crush, retract due to the rotation of the motor shaft)
 - Thermal hazard (e. g. burns due to touch on hot surfaces)
- These hazards are present while starting up and operating the unit, and also during servicing or maintenance work.
- Safety instructions in the documentation and on the product warn about the hazards.
- Personnel must have read and understood the safety instructions before installing and operating the product. In the documentation about the product the usage warnings pertain to direct hazards and must therefore be followed directly when operating or handling the product by the operator.
- AMKmotion products must be kept in their original order, that means it is not allowed to do a significant constructional change on hardware side and software is not allowed to be decompiled and change the source code.
- Damaged or faulty products are not allowed to be integrated or put into operation.
- Do not start the system in which the AMKmotion products are installed (begin of intended use) until you can determine that all relevant standards, laws, and directives have been complied with, e. g. low voltage directive, EMC directive, and the machinery directive, and possible further product standards. The plant manufacturer is responsible for the compliance with the laws, directives, and standards.
- The devices must be installed, electrically connected and operated as shown in the device description documentation. The technical data and the required environmental conditions must be observed at all times.

2.2 Safety rules for handling electrical systems



In particular on drive systems, the instructions pertaining to safety and the following five safety rules have to be kept in the specified sequence:

1. Switch off electrical circuits (also electronic and auxiliary circuits).
2. Secure against being switched on again.
3. Determine that there is no voltage.
4. Ground and short circuit.
5. Cover or close off neighboring parts that are under voltage.

Reverse the measures taken in reverse order after completing the work.





2.3 Presenting safety messages

Any safety information is configured as follows:





 SIGNAL WORD	
 Symbol	<p>Type and source of risk Consequence(s) of non-observance</p> <p>Steps to prevent:</p> <ul style="list-style-type: none"> • ...

2.4 Class of hazard

Safety and warning messages are graduated into classes of hazard (according to ANSI Z535). The class of hazard defines the potential risk of harm and is described by a single word, if the safety information is ignored. The signal word is followed by a safety alert symbol (ISO 3864, DIN EN ISO 7010). In accordance with ANSI Z535, the following signal words are used to define the class of hazard.

Safety alert symbol and signal word	Class of hazard and its meaning
	DANGER indicates a hazardous situation which, if not avoided, will result in death or serious injury
	WARNING indicates a hazardous situation which, if not avoided, could result in death or serious injury
	CAUTION, used with the safety alert symbol, indicates a hazardous situation which, if not avoided, could result in minor or moderate injury
	NOTICE is used to address preventions to avoid material damage, but not related to personal injury.

2.5 Safety alert symbols used

Safety symbol	Meaning
	Generic warning!
	Warning against dangerous electrical voltage!
	Warning against hot surface!
	Warning against magnetic field!

2.6 Intended use

The motors have been designed for use as drives in industrial commercial use, in machines and systems, and may only be operated within the specified limits (characteristic curve on motor data sheet and type plate). For use as intended, the motors have to be connected to an suitable AMK converter. Connecting the motors directly to the mains supply is prohibited and can lead to material damage!

Screws and ball screw nuts are exclusively intended for axial loads. Radial loads must be carried by external linear bearings.

Applications in the following areas are prohibited:

- Explosive environment
- Environment with oils, acids, gases, vapours, dust, radiation,...
- Environments that do not meet the climatic conditions that are required in this documentation.

The manufacturer / operator of the entire system is liable for damages caused by unintended use.

2.7 Requirements for the personnel and their qualification

Only authorized and qualified personnel may work on and with the AMKmotion drive systems.

Specialised personnel must:

- Perform mechanical and electrical work that is described in this documentation, such as mounting and connecting
- Observe all information in the documentation accompanying the product in order to work with the product safely and in an error-free manner
- Understand and know hazards that occur when handling the product
- Know connections and functions of the system
- Be familiar with the control concept in order to operate the drive system
- Be authorized to switch circuits and devices on and off, ground and label them
- Observe local specific safety requirements

2.8 CE mark

AMKmotion products have been constructed using the "State of the Art" and are safe to operate. AMKmotion issues an EU declaration of conformity for each of its products in which the standards and guidelines relevant for the product are listed. AMKmotion also designates the products with the CE mark which signifies conformity to the standards. Since these standards are listed in the Official Journal of the EU, it can be assumed through their application that the product meets the basic safety and health requirements of the harmonization regulation, the so-called presumption of conformity applies.

2.9 Warranty

- All information in the documents accompanying the product must be complied with for a safe and trouble-free operation.
- The assertion of warranty claims is excluded if the information in the documents is not observed completely.
- Hardware and firmware may not be modified except by personnel authorized by AMKmotion and after consultation with AMKmotion.
- The company AMKmotion GmbH + Co KG is not liable for damages from unintended use, incorrect installation or operation, exceeding rated values and non-observance with the environmental conditions.

3 Product overview

3.1 Product views

Motor SEZ 3

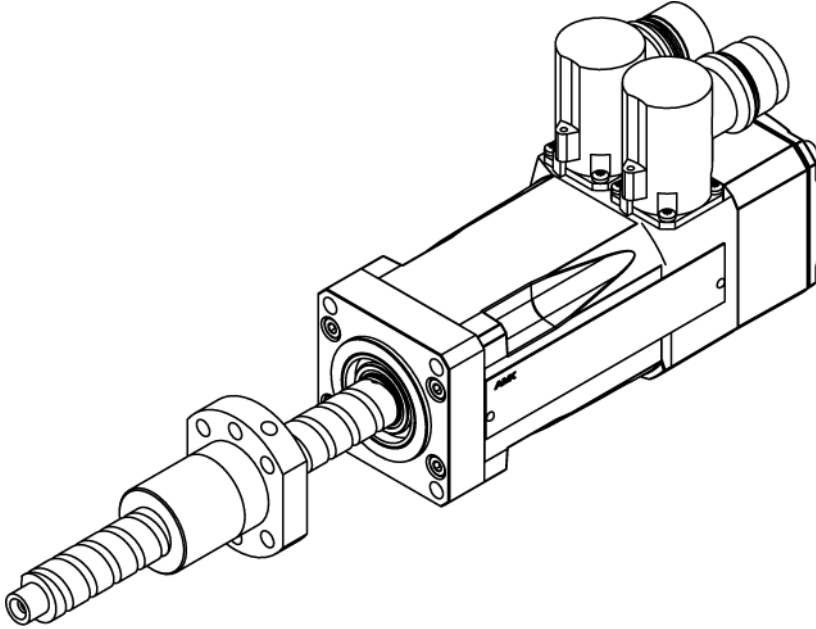

Motor SEZ 4

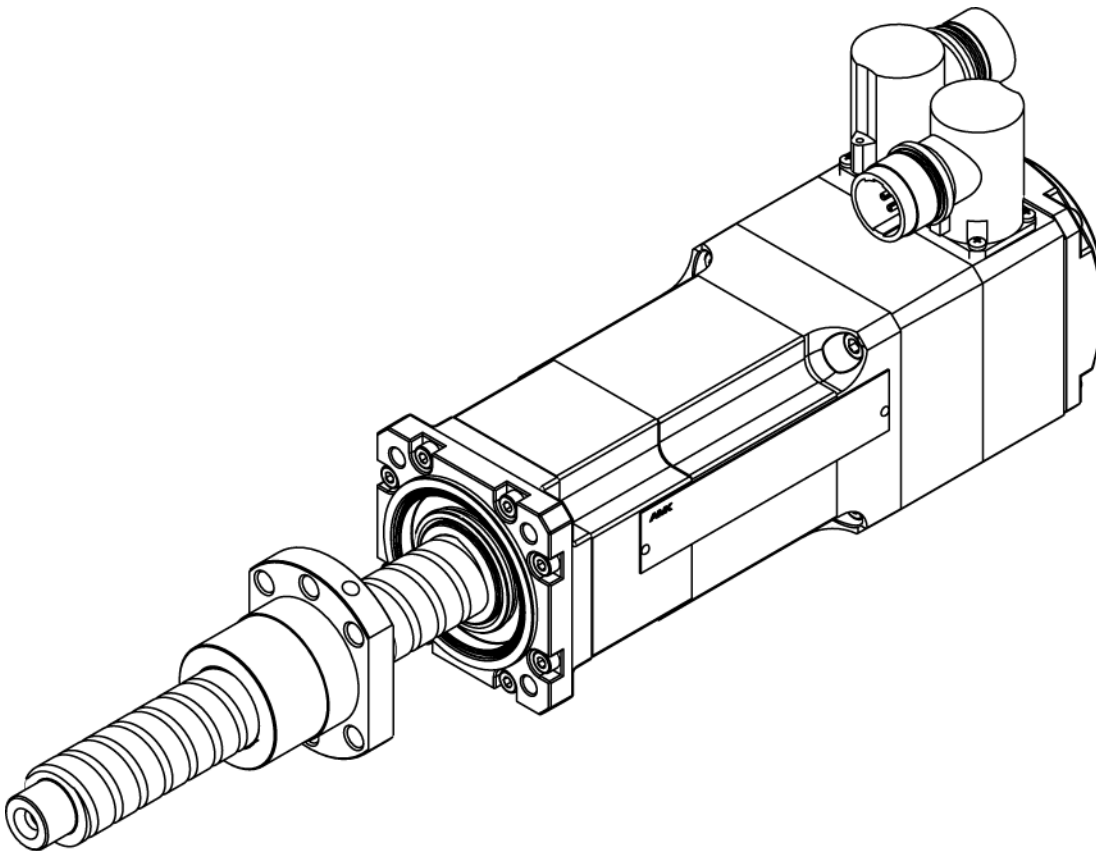

3.2 Variants of connections

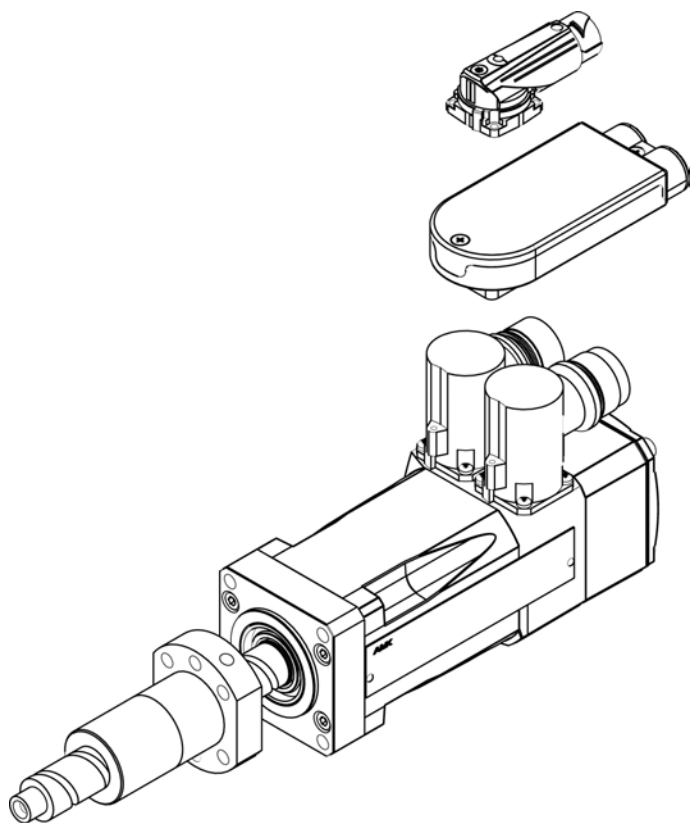

The SPINDASYN SEZ motor offers different variants of connection (top down):

- Hybrid connection M15 (only with Y-type encoders)
- ITT Cannon plug CM3
- Encoder and power plug M23

3.3 Type code

SEZ	x	-	x	-	x	-	x	-	x	x	x	x	-	x	-	x
																Device design:
																B5
																Theoretical idle speed [1/min]
																Cooling:
																O Convection cooling
																Holding brake / torque support:
																O No holding brake / torque support
																B With holding brake ¹⁾
																V With torque support
																P With holding brake and torque support ¹⁾
																Encoder:
																R Resolver
																E Singleturn absolute encoder EnDat 2.1, digital and SIN / COS track, optical
																F Multiturn absolute encoder EnDat 2.1, digital and SIN / COS track, optical
																P Singleturn absolute encoder EnDat 2.2 light, digital, inductive
																Q Multiturn absolute encoder EnDat 2.2 light, digital, inductive
																S Singleturn absolute encoder Hiperface, SIN / COS track, optical
																T Multiturn absolute encoder Hiperface, SIN / COS track, optical
																U Singleturn absolute encoder Hiperface, SIN / COS track, capacitive
																V Multiturn absolute encoder Hiperface, SIN / COS track, capacitive
																Y Singleturn / Multiturn absolute encoder Hiperface DSL, digital, optical
																Screw:
																K Ball screw KGT
																Maximum stroke [mm]
																Screw pitch[mm]
																Continuous standstill torque[Nm]
																Motor size:
																3 55 mm
																4 70 mm
SEZ	Spindasyn electric cylinder															

1) The motor holding brake is not approved for personal protection from suspended loads!

3.4 Type plate

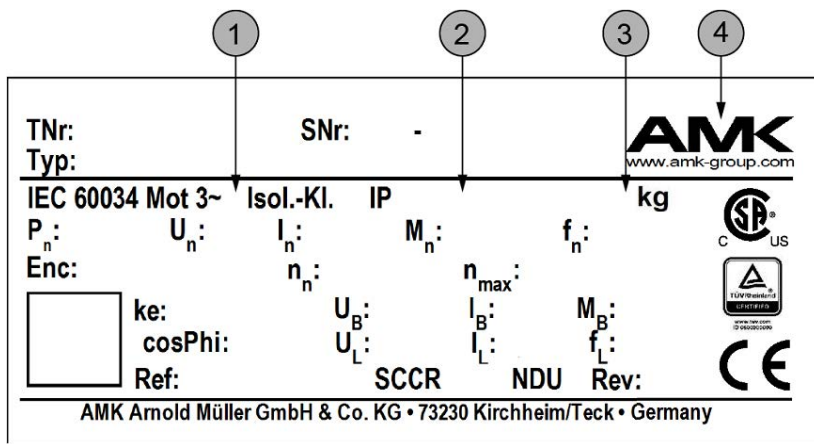



Illustration as an example: Content and scope can differ

Legend:

Abbreviation	Designation
1	Connection type
2	Duty type
3	Weight
4	Manufacturer
TNr	Part number
SNr	Serial number (year + calendar week – consecutive number)
Typ	Type designation
Isol.-Kl.	Insulation class
IP	Type of protection according to EN 60529
P _n	Rated power
U _n	Rated voltage
I _n	Rated current
M _n	Rated torque
f _n	Rated frequency
Enc	Motor encoder resolution
n _n	Rated speed
n _{max}	Max. speed of the output shaft of the system
ke	Voltage constant
U _B	Data on the motor holding brake: brake voltage
I _B	Data on the motor holding brake: brake current
M _B	Data on the motor holding brake: min. static brake torque
cosPhi	Power factor
U _L	Data on the fan: fan voltage

Abbreviation	Designation
I_L	Data on the fan: fan current
f_L	Data on the fan: fan frequency
Ref	Customer material number
SCCR	Short Circuit Current Rating
NDU	Non Dual-use
Rev	Revision

1		2		3		4		5			
 Arnold Müller GmbH & Co. KG D-73230 Kirchheim/Teck				S.-Nr.		—		VDE 0530-T1:1995 MOT 3~			
Type				T_R s		ISO.-KL.		LÜFTER / FAN		BREMSE / BRAKE	
P kW		M Nm		U V		I A		f Hz		U_{Br} V	
n / n_{max}		r/min		Encoder		P/Rev.		I_L A		I_{Br} A	
KD-Nr:						IP		f_L Hz		M_{Br} Nm	
16		15 14		13 12		11 10		9 8		7	
										6	

Legend for the type plate:

- 1 Manufacturer
- 2 Type designation
- 3 Rotor time constant
- 4 Serial number (part no. – calendar week + year – consecutive number)
- 5 Insulation class
- 6 Data on the motor brake (brake voltage, brake current and min. static brake torque)
- 7 Data on the fan (fan voltage, fan current and fan frequency)
- 8 Protection class
- 9 Rated frequency
- 10 Motor encoder resolution
- 11 Rated current
- 12 Rated speed of the motor / max. speed of the output shaft of the system
- 13 Rated voltage
- 14 Customer material number
- 15 Rated torque
- 16 Rated power

3.5 SEZ 3

3.5.1 Dimensional drawings

Side view

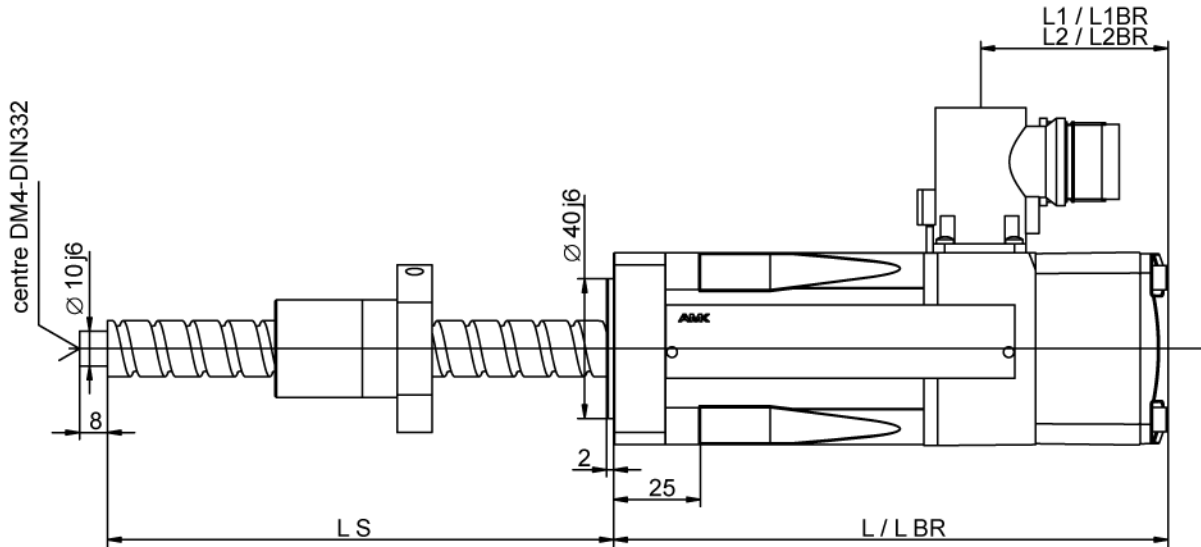

LS Screw length

L / L BR Motor length, depends on standstill torque, encoder type, brake

Front view

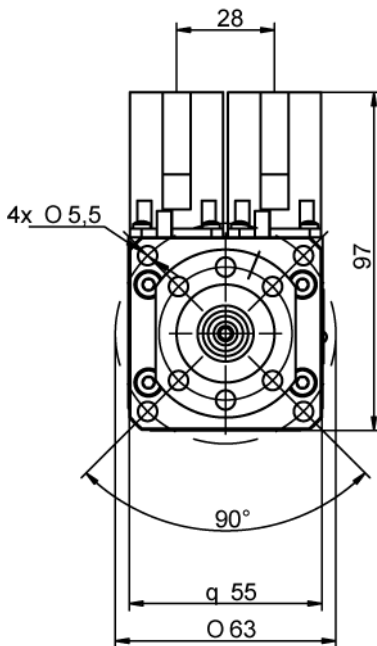

Dimensions of the screw nut: [Siehe 'Dimensional drawings' auf Seite 20.](#)

3.5.2 Technical data

Motor type		SEZ 3-0,5			SEZ 3-1		
Screw pitch	mm	5 mm	10 mm	16 mm	5 mm	10 mm	16 mm
Maximum axial force	kN	2,1	1,1	0,6	3,1 (4,8) ¹⁾	2,4	1,5
Nominal axial force	kN	0,7	0,34	0,2	1,7	0,8	0,5
Travel speed	m/s	0,37	0,73	1,17	0,37	0,73	1,17

1) limited by C_stat

Screw length 85 mm

Motor type		SEZ 3-0,5			SEZ 3-1		
Screw pitch	mm	5 mm	10 mm	16 mm	5 mm	10 mm	16 mm
Stroke length	mm	40	35	20	40	35	20
Inertia	kgcm ²	0,19	0,19	0,19	0,31	0,31	0,31
Acceleration	m/s ²	10	20	32	24	48	77

Screw length 115 mm

Motor type		SEZ 3-0,5			SEZ 3-1		
Screw pitch	mm	5 mm	10 mm	16 mm	5 mm	10 mm	16 mm
Stroke length	mm	70	65	50	70	65	50
Inertia	kgcm ²	0,21	0,21	0,21	0,33	0,33	0,33
Acceleration	m/s ²	9	18	29	21	42	67

Screw length 145 mm

Motor type		SEZ 3-0,5			SEZ 3-1		
Screw pitch	mm	5 mm	10 mm	16 mm	5 mm	10 mm	16 mm
Stroke length	mm	100	95	80	100	95	80
Inertia	kgcm ²	0,22	0,22	0,22	0,34	0,34	0,34
Acceleration	m/s ²	8	16	26	19	38	61

Screw length 205 mm

Motor type		SEZ 3-0,5			SEZ 3-1		
Screw pitch	mm	5 mm	10 mm	16 mm	5 mm	10 mm	16 mm
Stroke length	mm	160	155	140	160	155	140
Inertia	kgcm ²	0,25	0,25	0,25	0,37	0,37	0,37
Acceleration	m/s ²	7	14	22	16	32	51

Screw length 305 mm

Motor type		SEZ 3-0,5			SEZ 3-1		
Screw pitch	mm	5 mm	10 mm	16 mm	5 mm	10 mm	16 mm
Stroke length	mm	260	255	240	260	255	240
Inertia	kgcm ²	0,30	0,30	0,30	0,42	0,42	0,42
Acceleration	m/s ²	5,5	11	18	13	26	42

Screw length 405 mm

Motor type		SEZ 3-0,5			SEZ 3-1		
Screw pitch	mm	5 mm	10 mm	16 mm	5 mm	10 mm	16 mm
Stroke length	mm	360	355	340	360	355	340
Inertia	kgcm ²	0,35	0,35	0,35	0,47	0,47	0,47
Acceleration	m/s ²	4,6	9	15	11	22	35

3.6 SEZ 4

3.6.1 Dimensional drawings

Side view

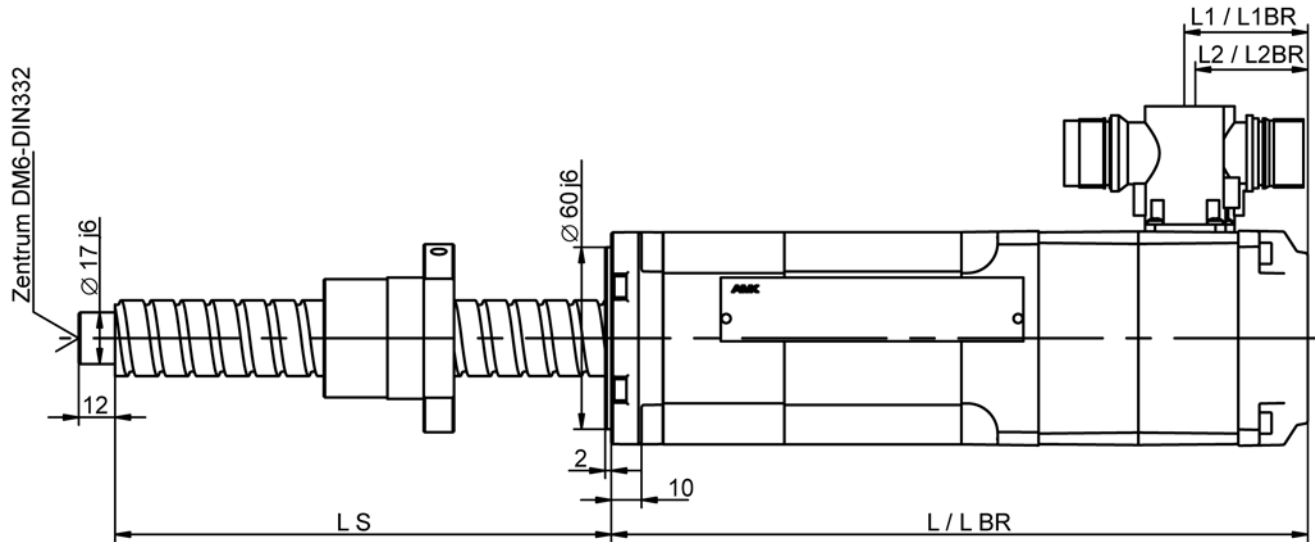

LS Screw length

L / L BR Motor length, depends on standstill torque, encoder type, brake

Front view

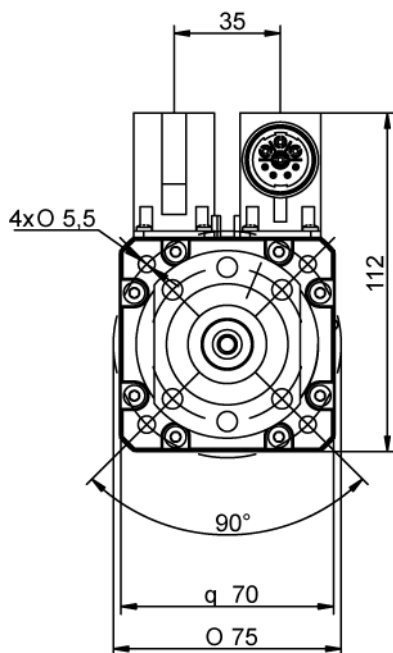

Dimensions of the screw nut: [Siehe 'Dimensional drawings' auf Seite 20.](#)

3.6.2 Technical data

Motor type		SEZ 4-1			SEZ 4-2		
Screw pitch	mm	5 mm	10 mm	25 mm	5 mm	10 mm	25 mm
Maximum axial force	kN	4,2	2,1	0,8	8,3	4,1	1,6
Nominal axial force	kN	1,3	0,7	0,3	2,5	1,3	0,5
Travel speed	m/s	0,23	0,46	1,15	0,23	0,46	1,15

Screw length 85 mm

Motor type		SEZ 4-1			SEZ 4-2		
Screw pitch	mm	5 mm	10 mm	25 mm	5 mm	10 mm	25 mm
Stroke length	mm	30	20	-	30	20	-
Inertia	kgcm ²	0,61	0,61	-	0,93	0,93	-
Acceleration	m/s ²	4,7	9,5	-	6,2	12,4	-

Screw length 115 mm

Motor type		SEZ 4-1			SEZ 4-2		
Screw pitch	mm	5 mm	10 mm	25 mm	5 mm	10 mm	25 mm
Stroke length	mm	60	50	40	60	50	40
Inertia	kgcm ²	0,70	0,7	0,70	1,02	1,02	1,02
Acceleration	m/s ²	4,1	8,2	20,6	5,7	11,3	28,3

Screw length 145 mm

Motor type		SEZ 4-1			SEZ 4-2		
Screw pitch	mm	5 mm	10 mm	25 mm	5 mm	10 mm	25 mm
Stroke length	mm	90	80	70	90	80	70
Inertia	kgcm ²	0,79	0,79	0,79	1,11	1,11	1,11
Acceleration	m/s ²	3,6	7,3	18,2	5,2	10,4	26,0

Screw length 205 mm

Motor type		SEZ 4-1			SEZ 4-2		
Screw pitch	mm	5 mm	10 mm	25 mm	5 mm	10 mm	25 mm
Stroke length	mm	150	140	130	150	140	130
Inertia	kgcm ²	0,98	0,98	0,98	1,30	1,30	1,30
Acceleration	m/s ²	3,0	5,9	14,8	4,5	8,9	22,3

Screw length 305 mm

Motor type		SEZ 4-1			SEZ 4-2		
Screw pitch	mm	5 mm	10 mm	25 mm	5 mm	10 mm	25 mm
Stroke length	mm	250	240	230	250	240	230
Inertia	kgcm ²	1,28	1,28	1,28	1,60	1,60	1,60
Acceleration	m/s ²	2,3	4,5	11,3	3,6	7,2	18,1

Screw length 405 mm

Motor type		SEZ 4-1			SEZ 4-2		
Screw pitch	mm	5 mm	10 mm	25 mm	5 mm	10 mm	25 mm
Stroke length	mm	350	340	330	350	340	330
Inertia	kgcm ²	1,58	1,58	1,58	1,90	1,90	1,90
Acceleration	m/s ²	1,8	3,7	9,1	3,0	6,1	15,2

3.7 Screw nut

3.7.1 Dimensional drawings

Side view (with fitting sleeve)

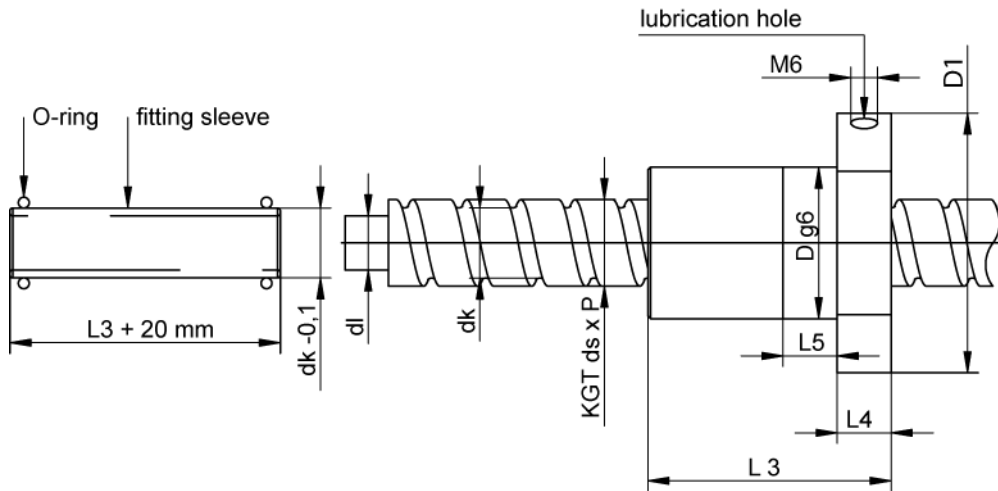

Front view

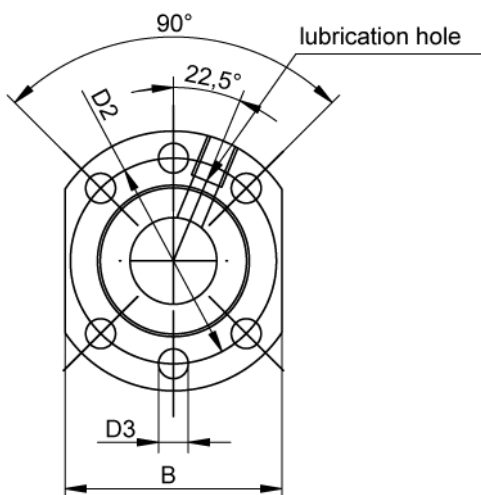

Dimension table

Motor type	Ball screw type	ds ± 0,1	P	D g6	D1	D2	D3	L3	L4	L5	B	dk	dl
SEZ 3	KGT 16 x 05	15,5	5	28	48	38	5,5	40	10	10	40	12,9	8
	KGT 16 x 10	14,6	10	28	48	38	5,5	45	10	10	40	12,5	8
	KGT 16 x 16	14,4	16	28	48	38	5,5	61	12	20	40	13	8
SEZ 4	KGT 25 x 05	24,9	5	40	62	51	6,6	43	10	12	48	22,3	10
	KGT 25 x 10	24,4	10	40	62	51	6,6	61	10	16	48	21,8	10
	KGT 25 x 25	24,7	25	40	62	51	6,6	70	10	16	48	22,1	10

3.7.2 Lead accuracy

The lead accuracy V300p describes the maximum deviation from the position setpoint in a randomly set length of 300 mm within the effective length of the screw ball drive.

SEZ motors are delivered with tolerance class 7 as standard. Other tolerance classes are possible on request.

Lead accuracy V300p

Tolerance class		5	7	10
Deviation	mm	0,023	0,052	0,21



3.8 Scope of delivery

Please check whether the delivered parts correspond with the delivery note. If the delivery is incomplete, please contact your nearest AMKmotion representative.

Check the components for signs of transport damage after their arrival. Do not install and operate any damaged components. If there is any transport damage, immediately inform the delivering freight carrier and inform your AMKmotion representative.

4 Projecting

4.1 Motor holding brake

 DANGER	
	<p>Risk of injury from hanging axes</p> <p>The optional motor brake is a holding brake and does NOT provide sufficient protection for persons. Hanging axes can fall and lead to severe injury.</p> <p>Steps to prevent:</p> <ul style="list-style-type: none"> • All hanging axes must be mechanically secured against falling with a fall arrester or a supplementary external brake, for instance. • People must not stand under hanging loads

NOTICE	
Material Damage!	<p>Material damage of the holding brake!</p> <p>The brake optional integrated into the motor is a holding brake. The holding brake can be irreparably damaged if it is used as main brake.</p> <p>Steps to prevent:</p> <ul style="list-style-type: none"> • Make sure that the motor holding brake is open, when movement commands are sent to the motor. • Make sure that the motor holding brake only closes after the motor shaft has come to a standstill.

The motors can be optionally equipped with a motor holding brake (spring-loaded brake). The brakes are opened using 24 V DC (unsmoothed). The speed thresholds of the brake must not be exceeded by the application. The brake is connected directly to the AMK converter and is automatically controlled by the converter.

If the brake opens while the motor shaft is rotating (e.g. in the case of a mains failure), the operator of the machine subsequently has to ensure that the brake is fully functional before starting up the machine again.

4.2 Balance quality grade

Power transmission elements, e.g. coupling, belt pulley or toothed gear, have to correspond to the balance quality grade of the motor.

See technical data

4.3 Overview of motor encoders

The listed data of the encoders are typical standard values and might differ for the respective motor.

Encoder type	Technical description	Manufacturer / designation
R	<ul style="list-style-type: none"> • Absolute encoder • Singleturn • Analog 	Tyco V23401-D1001
	Resolution: 1 period/revolution	
	Measuring principle: resolver	
E	<ul style="list-style-type: none"> • Absolute encoder • Singleturn • Digital • Analog 	Heidenhain ECN 113 ECN 1113 ECN 1313
	Digital resolution: 13 bit/revolution	
	Analog resolution: 512 / 2048 periods/revolution	
	Measuring principle: optical	
	Protocol: EnDat 2.1	
	Electronic type plate	
F	<ul style="list-style-type: none"> • Absolute encoder • Multiturn • Digital • Analog 	Heidenhain EQN 1125 EQN 1325
	Digital resolution: 13 bit/revolution	
	Analog resolution: 512 / 2048 Periods/revolution	
	Measuring principle: optical	
	Protocol: EnDat 2.1	
	Electronic type plate	
P	<ul style="list-style-type: none"> • Absolute encoder • Singleturn • Digital 	Heidenhain ECI 1118 ECI 1319 ECI 119
	Resolution: 18 / 19 bit/revolution ²⁾	
	Measuring principle: inductive, permanent magnets	
	Protocol: EnDat 2.2 light	
	Electronic type plate	
Q	<ul style="list-style-type: none"> • Absolute encoder • Multiturn • Digital 	Heidenhain EQI 1130 EQI 1331
	Resolution: 18 / 19 bit/revolution ²⁾	
	Measuring principle: inductive	
	Protocol: EnDat 2.2 light	
	Electronic type plate	

Encoder type	Technical description	Manufacturer / designation
S	<ul style="list-style-type: none"> • Absolute encoder • Singleturn • Digital • Analog 	Sick Stegmann SKS 36 SRS 50
	Digital resolution: 15 bit/revolution	
	Analog resolution: 128 / 1024 periods/revolution	
	Measuring principle: optical	
	Protocol: Hiperface	
	Electronic type plate	
T	<ul style="list-style-type: none"> • Absolute encoder • Multiturn • Digital • Analog 	Sick Stegmann SKM 36 SRM 50
	Digital resolution: 15 bit/revolution	
	Analog resolution: 128 / 1024 periods/revolution	
	Measuring principle: optical	
	Protocol: Hiperface	
	Electronic type plate	
U	<ul style="list-style-type: none"> • Absolute encoder • Singleturn • Digital • Analog 	Sick Stegmann SEK 37
	Digital resolution: 9 bit/revolution	
	Analog resolution: 16 periods/revolution	
	Measuring principle: capacitive	
	Protocol: Hiperface	
	Electronic type plate	
V	<ul style="list-style-type: none"> • Absolute encoder • Multiturn • Digital • Analog 	Sick Stegmann SEL 37
	Digital resolution: 9 bit/revolution	
	Analog resolution: 16 periods/revolution	
	Measuring principle: capacitive	
	Protocol: Hiperface	
	Electronic type plate	

Encoder type	Technical description	Manufacturer / designation
Y	<ul style="list-style-type: none"> • Absolute encoder • Singleturn • Multiturn • Digital 	Sick Stegmann singleturn: EKS 36 EFS 50
	Resolution: 17 / 20 / 23 bit/revolution	
	Measuring principle: optical	
	Protocol: Hiperface DSL	
	Electronic type plate	

2) depends on motor size

For detailed information about motor encoders:
See document Device description Motor encoders (Part no. 27859)

5 Transport and storage

5.1 Transport

⚠ DANGER	
	<p>Risk of injury from crushing, cutting and hitting. When transporting and mounting sharp-edged and / or heavy components, there is a risk of crushing, cutting and bruising of the persons involved. Suspended loads can fall down and people suffer fatal injuries.</p> <p>Steps to prevent:</p> <ul style="list-style-type: none"> • Utilize suitable assembly and transport equipment, such as hoists and carriages. • Wear protective clothing, e.g. safety gloves and boots, during the assembly. • Use only appropriate tools during the assembly. • Make sure that there are no persons or body parts located under suspended loads during the transport or assembly. • Prevent catching and crushing by mechanical devices.

NOTICE	
Material Damage!	<p>Material damage when lifting and transporting the motor! The motors may not be lifted and transported by</p> <ul style="list-style-type: none"> • the shaft • the connectors • the terminal box <p>Steps to prevent:</p> <ul style="list-style-type: none"> • Lift the motor by the lifting lugs screwed in for this purpose. • Motors without lifting lugs can be lifted with two loop hoisting slings that are attached around the motor housing. • Motors with lifting lugs may also be lifted with loop hoisting slings when the main force is not applied to any of the above listed parts. • The existing holes and threads for mounting the motor can be used for transportation purposes. Damage to the flange surface and the fittings attached there to the shaft and housing must be avoided.

Check the components for signs of transport damage after their arrival. Do not install and operate any damaged components.

The fit diameters and flange surfaces are partly coated with peel-off protective paint (film), which has to be completely removed during installation and for operation, without leaving any residue.



5.2 Storage



- For storage periods of up to 2 years under storage conditions compliant with EN 61800-2, no special measures are needed prior to startup.
- Store the motors with the shaft in a horizontal position.
- Room temperature between +5 °C and +40 °C
- Relative humidity max. 60 %
- Clean, dry, vibration-free, protected against weather conditions
- Protected against sudden temperature and humidity changes
- Protected against salt fog, industrial fumes, corroding liquids, vermin and mildew
- Avoid contact corrosion.
- The circuits of the liquid cooling have to be emptied and purged with air.
- Protect bare external parts with a preservation agent, e.g.: Oil the shaft ends or coat with peel-off paint, if this has not already been done at the factory.

If the motors are stored incorrectly there is risk of bearing damage such as brinelling, for example as a result of vibration.

6 Assembly

6.1 For your safety

 DANGER	
	<p>Risk of injury from crushing, cutting and hitting.</p> <p>When transporting and mounting sharp-edged and / or heavy components, there is a risk of crushing, cutting and bruising of the persons involved. Suspended loads can fall down and people suffer fatal injuries.</p> <p>Steps to prevent:</p> <ul style="list-style-type: none"> • Utilize suitable assembly and transport equipment, such as hoists and carriages. • Wear protective clothing, e.g. safety gloves and boots, during the assembly. • Use only appropriate tools during the assembly. • Make sure that there are no persons or body parts located under suspended loads during the transport or assembly. • Prevent catching and crushing by mechanical devices.

 DANGER	
	<p>Danger to life from touching electrical connections!</p> <p>The permanent magnets of the rotor induce dangerous voltage at the motor connections when the axis rotates, even when the motor is not electrically connected. If the motor is connected to an inverter, the induced DC voltage is linked to the terminals UZP and UZN for the DC bus.</p> <p>Steps to prevent:</p> <ul style="list-style-type: none"> • Make sure that the motor shaft does not rotate. • Make sure that shock-hazard protection is installed at the motor connections. • Make sure that the terminals are free of voltage.

6.2 Avoiding material damage

NOTICE	
Material Damage!	<p>Material damage when lifting and transporting the motor!</p> <p>The motors may not be lifted and transported by</p> <ul style="list-style-type: none"> • the shaft • the connectors • the terminal box <p>Steps to prevent:</p> <ul style="list-style-type: none"> • Lift the motor by the lifting lugs screwed in for this purpose. • Motors without lifting lugs can be lifted with two loop hoisting slings that are attached around the motor housing. • Motors with lifting lugs may also be lifted with loop hoisting slings when the main force is not applied to any of the above listed parts. • The existing holes and threads for mounting the motor can be used for transportation purposes. Damage to the flange surface and the fittings attached there to the shaft and housing must be avoided.

NOTICE

Material Damage!	<p>Material damage caused by incorrect assembly!</p> <p>The mounting flange of the motor has to lie evenly on the surface to which it will be mounted, else mechanical tension could occur when the fastening screws are tightened.</p>
	<p>Steps to prevent:</p> <ul style="list-style-type: none"> • Before tightening the fastening screws, check whether the flange is lying evenly on the surface to be mounted.

NOTICE

Material Damage!	<p>Material damage caused by impact to the motor shaft!</p> <p>All impacts to the shaft can cause damage to the bearings or encoder.</p>
	<p>Steps to prevent:</p> <ul style="list-style-type: none"> • Use the specified tools and equipment for mounting drive elements • Use the threading provided to tighten the attachment parts to the fits with using the fastening screws.

NOTICE

Material Damage!	<p>Material damage to temperature-sensitive parts</p> <p>The surfaces of the motors can get up to 140 °C hot during operation and could damage neighbouring or adjacent objects.</p>
	<p>Steps to prevent:</p> <ul style="list-style-type: none"> • When positioning temperature-sensitive parts, e.g. lines, plastic covers, etc., make sure that these do not make contact with the motor casing.

6.3 Prerequisites and preparations

- Check the components for signs of transport damage after their arrival. Do not install and operate any damaged components.
- Any transport protection that might be present (protective foil, cardboard covers, corrosion protection agent on the shaft...) has to be removed prior to installation.
- Observe the motor data sheet's specifications on the permissible radial forces and the axial forces of the motor output shaft.
- Make sure that the ambient conditions required for the motor are met.
- The installation position for the specific Motor please find on the motor data sheet. In the case of a vertical installation position, care must be taken that no liquid can enter the upper bearing. Please contact AMK!

6.4 Tightening torques

Unless otherwise specified, all of the screw connections are to be tightened with the following torques:

Tightening torques for screws with a connecting surface

Dimension	Tightening torque [Nm]
	Property class 8.8 Coefficient of friction $\mu_{\text{total}} = 0,125$
M4	2.8
M5	5.5
M6	9.6
M8	23
M10	46
M12	79
M14	125
M16	195
M18	280
M20	395
M22	540
M24	680
M27	1000
M30	1350

6.5 Pushing and pulling drive elements on and off

- Couplings, toothed gears and belt pulleys may only be pushed on or pulled off with appropriate equipment.
- Use a threaded bore (DM design as per DIN 332, i.e. with metric thread) in the shaft end. Observe the tightening torques for screws and bolts.
- Heat up the drive elements if necessary.
- When pulling off drive elements, use a spacer disc to protect the centring in the shaft end.
- If necessary, balance the complete motor, with the drive elements, in acc. with ISO 1940.
- Take notice of the permissible axial force specified in the motor data sheet

6.6 Initial lubrication of the screw nut

An adequate lubrication of the ball screw nut is prerequisite for functionality and a long lifetime.

Ex works, the screw nuts are merely conserved. During start-up, the screw nut must be lubricated. The conserving oil is compatible to the lubricants recommended below.

The respective quantity of lubricant according to the following table has to be put to the screw nut in three parts. In between, the nut has to be moved for 2 - 3 nut lengths.

For short stroke use, if the stroke is less than twice the nut length, put the lubricant to the screw nut at several positions of the nut.

Lubricant quantity for ball screw drives with grease lubrication

	Ball screw drive	Lubrication quantity [cm ³]	
		Initial lubrication	Re-lubrication
SEZ 3	KGT 16x05	0,2 (3x)	0,4
	KGT 16x10	0,4 (3x)	0,8
	KGT 16x16	0,3 (3x)	0,6
SEZ 4	KGT 25x05	0,6 (3x)	1,2
	KGT 25x10	0,7 (3x)	1,4
	KGT 25x25	0,8 (3x)	1,6

Recommended greases:

- Klüber Klüberquiet® BQH 72-102
- Klüber ISOFLEX® TOPAS NCA 52

In general, the same greases can be used for screw nuts as for rolling bearings. So the kind of feed and the grease type can be adapted to the other machine components.



You will get information about grease types and lubrication intervals from the respective motor data sheet.

6.7 Convection-cooled motors

The rated data of the motors apply up to an ambient temperature of max. 40 °C. To ensure adequate heat dissipation in convection-cooled motors, 3 side surfaces of the motor have to be at least 100 mm away from neighbouring components.

7 Electrical connections

7.1 EMC-compliant connections

The motor is adequately protected against incoming and outgoing electromagnetic radiation by means of a metallic conductive casing.

During operation of the converter, high-frequency current and voltage peaks in the motor lines can cause electromagnetic interferences. Only use shielded cables for power and signal lines. The braided shield of the encoder and power cable has to be connected on both sides. With the plug connectors available from AMK, the cable shield can be connected in compliance with EMC regulations.

The power cables and signal lines have to be laid spatially apart.

7.2 Phase sequence

The phase sequence (for power and encoder connection) and the zero position of the encoder (field orientation of the rotation with respect to the commutation) are attuned to operation with AMK converters. When the motor rotates clockwise (viewpoint: towards the motor shaft), voltage is induced with ascending phase sequence U-V-W. If AMK motors are operated with converters that are not from AMK, it might be necessary to switch two phases of the power connection and adapt the zero position of the encoder.

7.3 Connection diameters

Extract from EN 60204-1:1997, table 5

Cross-section [mm ²]	Current load [A_{eff}] for machines and systems	AWG diameter
0,75	-	20
1	11,7	18
1,5	15,2	16
2,5	21	14
4	28	12
6	36	10
10	50	8
16	66	6
25	84	4
35	104	2
50	123	1
70	155	00
95	192	000
120	221	0000

7.4 Encoder connection

7.4.1 Encoder plug M23

NOTICE	
Material Damage!	<p>Material damage when plugging in the</p> <p>The plug must be aligned before insertion into the socket. The pin contacts are engaged before the codings of the plug and socket interlock. The pin contacts will be bent if the plug is turned when being inserted and the pin contacts are already engaged or if the plug and socket are not properly aligned and the screwcap is tightened.</p> <p>Steps to prevent:</p> <ul style="list-style-type: none"> • The plug must be inserted when aligned with the socket. • Only turn the plug if the pin contacts are not yet engaged. • Only tighten the screwcap once the codings of the plug and socket interlock.

NOTICE

Material Damage!

Damage to the rotatable right-angle connector!

The angular connector can be rotated and aligned as desired with the plugged-in and screw-tightened mating connector (approx. 16 locking positions). For alignment, a torque of approx. >8 Nm is required. The alignment makes variable mounting positions and an adaptable motor connection possible.

If the connector is frequently re-aligned, or aligned without a mating connector, by means of pliers or other tools, the thread of the screwcap can be destroyed and the sealing surface damaged.

Steps to prevent:

- Only turn the connector if the mating connector is in place.
- Do not use any pliers or other tools
- The connector must not make any permanent movements.
- To ensure that the protection class is upheld, max. 10 turns are permitted.



The screwcap has to be plugged in and screwed on up to the mark, else the pins do not make contact and encoder errors can occur.

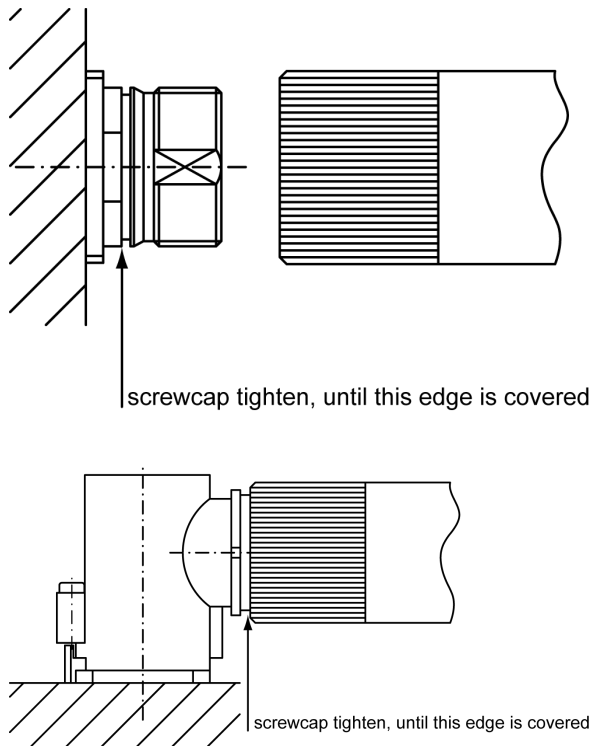

Description:

The encoder plug at the motor is connected to the encoder input on the converter by means of the encoder cable. If necessary, equip the connection cable with twist, strain and shear relief, as well as kink protection. Forces that act on the connector permanently are not permissible!

Technical data:

The maximum permitted length of the cable is specified by the converter connection.

Design:

Type	Pins	Class
Encoder plug M23, metal	12	Built-in box with male contacts

Assignment:

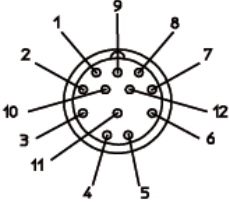
Drawing	Connection	Signals			Description
		E-, F-, P-, Q-encoder ³⁾	S-, T-, U-, V-encoder	Resolver	
Front view of the device side 	1	+SIN	+SIN	+SIN	Analogue track 2 not inverted
	2	-SIN	-SIN	-SIN	Analogue track 2 inverted
	3	+COS	+COS	+COS	Analogue track 1 not inverted
	4	-COS	-COS	-COS	Analogue track 1 inverted
	5	5 VDC ¹⁾	-	-	Supply VDC
	6	GND	GND	-	Reference for the supply
	7	+EN_CLK	-	-	Encoder specific signal
	8	-EN_CLK	Shield	-	Encoder specific signal
	9	+EN_DAT	+RS485	+Uref	Encoder specific signal
	10	-EN_DAT	-RS485	-Uref	Encoder specific signal
	11	5 VDC ¹⁾	8 VDC ²⁾	-	Supply VDC
	12	GND	-	-	Reference for the supply
	Shield	Plug housing			

1) 5 VDC ±5 %, max. 250 mA

2) 8 VDC ±5 % with load, max. 250 mA; 9 VDC ±20 % at no-load

3) P- und Q-encoder with analogue track can be parameterised in ID32953 and operated like E- and F-encoder

Connection:

Mating plug	Encoder plug M23, female, 12-poles
Cable	4 x (2 x 0.25 mm ²) twisted-pair + 4 x 0.5 mm ² / AWG 24 + AWG 20, shielded
Shield connection	Apply on both sides
Accessories	Prefabricated cables: Siehe 'Encoder cable with M23-plug configured' auf Seite 68.

Circuit principle:

shield place over plug housing

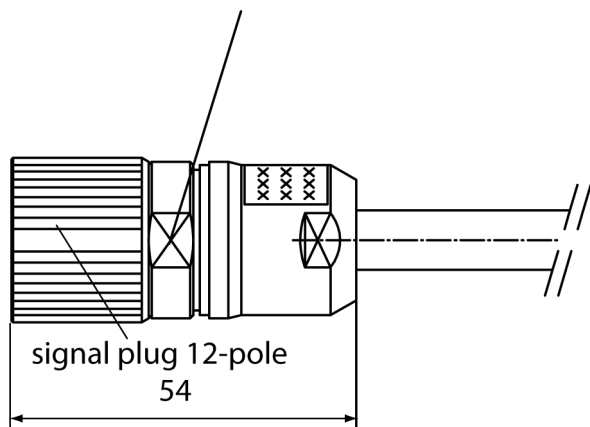

shield place over plug housing

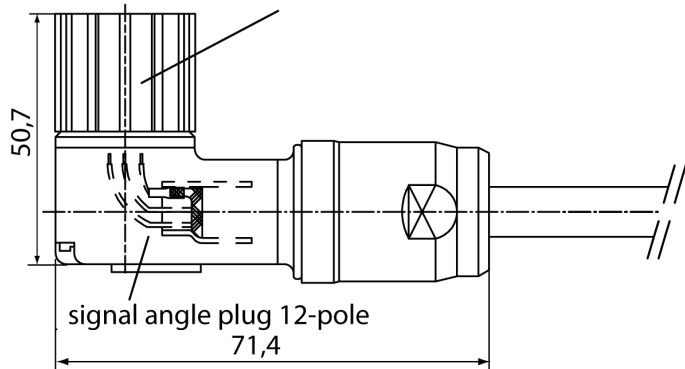

7.4.1.1 Encoder plug M23 - Siemens compliant

NOTICE

Material Damage!

Material damage when plugging in the

The plug must be aligned before insertion into the socket. The pin contacts are engaged **before** the codings of the plug and socket interlock. The pin contacts will be bent if the plug is turned when being inserted and the pin contacts are already engaged or if the plug and socket are not properly aligned and the screwcap is tightened.

Steps to prevent:

- The plug must be inserted when aligned with the socket.
- Only turn the plug if the pin contacts are not yet engaged.
- Only tighten the screwcap once the codings of the plug and socket interlock.

NOTICE

Material Damage!

Damage to the rotatable right-angle connector!

The angular connector can be rotated and aligned as desired with the plugged-in and screw-tightened mating connector (approx. 16 locking positions). For alignment, a torque of approx. >8 Nm is required. The alignment makes variable mounting positions and an adaptable motor connection possible.

If the connector is frequently re-aligned, or aligned without a mating connector, by means of pliers or other tools, the thread of the screwcap can be destroyed and the sealing surface damaged.

Steps to prevent:

- Only turn the connector if the mating connector is in place.
- Do not use any pliers or other tools
- The connector must not make any permanent movements.
- To ensure that the protection class is upheld, max. 10 turns are permitted.



The screwcap has to be plugged in and screwed on up to the mark, else the pins do not make contact and encoder errors can occur.

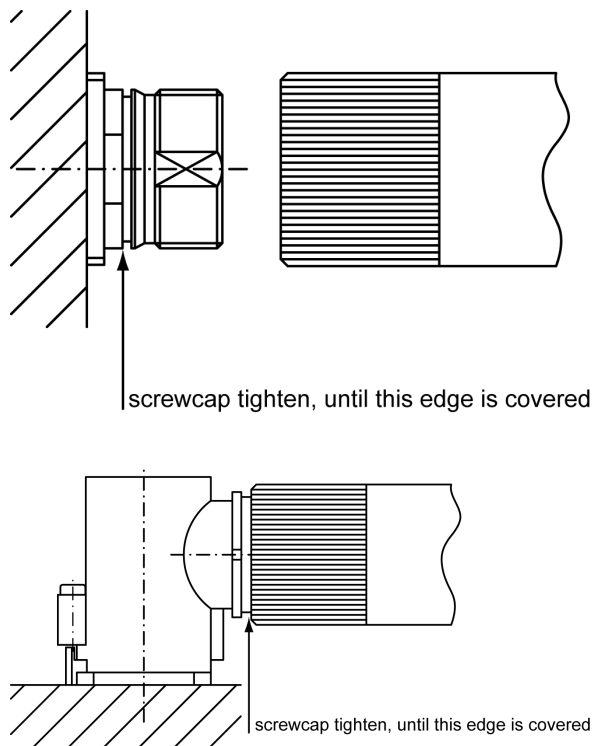

Description:

The encoder plug at the motor is connected to the encoder input on the converter by means of the encoder cable. If necessary, equip the connection cable with twist, strain and shear relief, as well as kink protection. Forces that act on the connector permanently are not permissible!

Technical data:

The maximum permitted length of the cable is specified by the converter connection.

Design:

Type	Pins	Class
Encoder plug M23, metal	17	Built-in box with male contacts

Assignment:

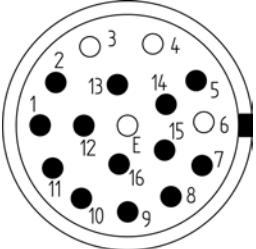
Drawing	Connection	Signals	Description
Front view of the device side 	1	G1N (+COS)	Analogue track 1 not inverted
	2	G1I (-COS)	Analogue track 1 inverted
	3	DAT+	Encoder specific signal
	4	-	-
	5	CLK+	Encoder specific signal
	6	-	-
	7	GND	Reference for the supply
	8	TH+	Temperature sensor motor winding +
	9	TH-	Temperature sensor motor winding -
	10	5P	Supply VDC
	11	G2N (+SIN)	Analogue track 2 not inverted
	12	G2I (-SIN)	Analogue track 2 inverted
	13	DAT-	Encoder specific signal
	14	CLK-	Encoder specific signal
	15	GND	Reference for the supply
	16	5P	Supply VDC
	E	-	-
Shield	Plug housing		

Connection:

Mating plug	Encoder plug M23, female, 17-poles
Recommended cable cross section	shielded 4 x (2 x 0.25 mm ²) twisted-pair + (4 x 0.5 mm ²) + (2 x 0.75 mm ²)
Shield connection	Apply on both sides

7.4.1.2 Encoder plug M23 - PacDrive3 compliant

NOTICE	
Material Damage!	<p>Material damage when plugging in the</p> <p>The plug must be aligned before insertion into the socket. The pin contacts are engaged before the codings of the plug and socket interlock. The pin contacts will be bent if the plug is turned when being inserted and the pin contacts are already engaged or if the plug and socket are not properly aligned and the screwcap is tightened.</p> <p>Steps to prevent:</p> <ul style="list-style-type: none"> • The plug must be inserted when aligned with the socket. • Only turn the plug if the pin contacts are not yet engaged. • Only tighten the screwcap once the codings of the plug and socket interlock.

NOTICE

Material Damage!

Damage to the rotatable right-angle connector!

The angular connector can be rotated and aligned as desired with the plugged-in and screw-tightened mating connector (approx. 16 locking positions). For alignment, a torque of approx. >8 Nm is required. The alignment makes variable mounting positions and an adaptable motor connection possible.

If the connector is frequently re-aligned, or aligned without a mating connector, by means of pliers or other tools, the thread of the screwcap can be destroyed and the sealing surface damaged.

Steps to prevent:

- Only turn the connector if the mating connector is in place.
- Do not use any pliers or other tools
- The connector must not make any permanent movements.
- To ensure that the protection class is upheld, max. 10 turns are permitted.



The screwcap has to be plugged in and screwed on up to the mark, else the pins do not make contact and encoder errors can occur.

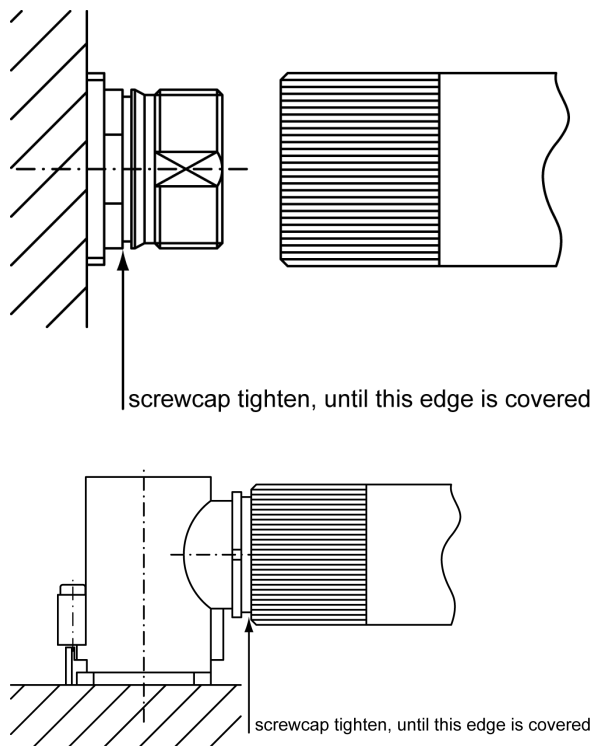

Description:

The encoder plug at the motor is connected to the encoder input on the converter by means of the encoder cable. If necessary, equip the connection cable with twist, strain and shear relief, as well as kink protection. Forces that act on the connector permanently are not permissible!

Technical data:

The maximum permitted length of the cable is specified by the converter connection.

Design:

Type	Pins	Class
Encoder plug M23, metal	12	Built-in box with male contacts

Assignment:

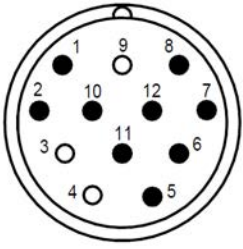
Drawing	Connection	Signals	Description
Front view of the device side 	1	G1I (-COS)	Analogue track 1 inverted
	2	G0N (+RS485)	Encoder specific signal
	3	n. c.	-
	4	n. c.	-
	5	G2N (+SIN)	Analogue track 2 not inverted
	6	G2I (-SIN)	Analogue track 2 inverted
	7	G0I (-RS485)	Encoder specific signal
	8	G1N (+COS)	Analogue track 1 not inverted
	9	n. c.	-
	10	GND	Reference for the supply
	11	Shield	Shield
	12	+9V	Supply VDC

Connection:

Mating plug	Encoder plug M23, female, 17-poles
Recommended cable cross section	shielded 4 x (2 x 0.25 mm ²) twisted-pair + (4 x 0.5 mm ²)
Shield connection	Apply on both sides

7.4.2 Encoder plug CM3

NOTICE

Material Damage!	<p>Material damage when plugging in the</p> <p>The plug must be aligned before insertion into the socket. The pin contacts are engaged before the codings of the plug and socket interlock. The pin contacts will be bent if the plug is turned when being inserted and the pin contacts are already engaged or if the plug and socket are not properly aligned and the screwcap is tightened.</p> <p>Steps to prevent:</p> <ul style="list-style-type: none"> The plug must be inserted when aligned with the socket. Only turn the plug if the pin contacts are not yet engaged. Only tighten the screwcap once the codings of the plug and socket interlock.
-------------------------	---

Description:

The encoder plug at the motor is connected to the encoder input on the converter by means of the encoder cable. If necessary, equip the connection cable with twist, strain and shear relief, as well as kink protection. Forces that act on the connector permanently are not permissible!

Technical data:

The maximum permitted length of the cable is specified by the converter connection.

Design:

Type	Poles	Sort	Manufacturer	Designation
-	6	Female	ITT-Cannon	Insulator red for plug CM3 [X05.1]
-	6	Female	ITT-Cannon	Insulator blue for plug CM3 [X05.2]

Assignment:

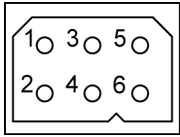
[X05.1] CM3-plug	Connection	Signals			Description
		Resolver	E-, F-, P-, Q-encoder ³⁾	S-, T-, U-, V-encoder	
Front view of the device side 	1	+Uref	+EN_DAT	-	Encoder specific signal
	2	-Uref	-EN_DAT	-	Encoder specific signal
	3	-	GND	-	Reference for the supply
	4	-	5 VDC ¹⁾	-	Supply VDC
	5	-	-EN_CLK	-RS485	Encoder specific signal
	6	-	+EN_CLK	+RS485	Encoder specific signal
	Shield	Plug housing			

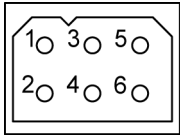
[X05.2] CM3-plug	Connection	Signals			Description
		Resolver	E- / F- / P-, Q-encoder ³⁾	S- / T-, U- / V-encoder	
Front view of the device side 	1	-	-	GND	Reference for the supply
	2	-	-	8 VDC ²⁾	Supply VDC
	3	+SIN	+SIN	+SIN	Analogue track 2 not inverted
	4	-SIN	-SIN	-SIN	Analogue track 2 inverted
	5	+COS	+COS	+COS	Analogue track 1 not inverted
	6	-COS	-COS	-COS	Analogue track 1 inverted
	Shield	Plug housing			

1) 5 VDC ±5 %, max. 250 mA

2) 8 VDC ±5 % with load, max. 250 mA; 9 VDC ±20 % at no-load

3) P- und Q-encoder with analogue track can be parameterised in ID32953 and operated like E- and F-encoder

Siehe 'Handling of the CM3-plug (ITT-Cannon)' auf Seite 49.

Connection:

Mating plug	2 x 6-poles, male
Cable	4 x (2 x 0,25 mm ²) twisted pair + 4 x 0,5 mm ² / AWG 24 + AWG 20, shielded
Shield connection	Apply on both sides
Accessories	Prefabricated cables: in preparation

7.5 Power connection

7.5.1 For your safety

⚠ DANGER	
	<p>Danger to life from touching electrical connections!</p> <p>Electrical terminals and connectors carry voltages that may cause death or serious injury upon contact.</p> <p>Steps to prevent:</p> <ul style="list-style-type: none"> • Prior to any work on the device: Observe the 5 safety rules. • Measure the terminal voltages. There may be no voltage present. • Plug and pull connections only when there is no voltage. • For devices that are connected to a DC bus, or generate it yourself, you need to consider the discharge times of the dc bus capacitors mentioned in the converter documentation • Before commencing work, the connections must be isolated from the voltage supply at both ends! (both ends mean: AC and DC bus supply side)

⚠ DANGER



Danger to life from electrical shock!

In the event of an interruption to the PE connection, avoid touching the casing because life-threatening levels of voltage may be present!

Steps to prevent:

- EN 61800-5-1 requires that the devices be firmly connected on the power side.

⚠ DANGER



Danger to life from touching electrical connections!

The permanent magnets of the rotor induce dangerous voltage at the motor connections when the axis rotates, even when the motor is not electrically connected. If the motor is connected to an inverter, the induced DC voltage is linked to the terminals UZP and UZN for the DC bus.

Steps to prevent:

- Make sure that the motor shaft does not rotate.
- Make sure that shock-hazard protection is installed at the motor connections.
- Make sure that the terminals are free of voltage.

7.5.2 Avoiding material damage

NOTICE

Material Damage!

On the open unit a dry, non-conductive pollution may only occur. The penetrating pollution into the open housing may not affect the functionality of the device (EN 61800-5-1, pollution degree 1). Ensure that no objects fall into the housing when working on the open housing. Foreign objects can cause short-circuits during operation and thereby destroy the device.

NOTICE

Material Damage!

Material damage resulting from incorrect motor connection!

The motors will be irreparably damaged if they are connected directly to the phases of the supply network without a converter.

Steps to prevent:

- Always operate the motor with a converter that is suitable for the motor and the application.
- Observe the information in the documentation of the converter.

NOTICE

Material Damage!

Material damage resulting from Overheating!

AMK servo motors are provided with sensors for temperature monitoring. Motors without or with bypassed sensors for temperature can overheat and be destroyed.

Steps to prevent:

- Connect the sensors for temperature of the servo motor for temperature monitoring
- Activate the I²t monitoring of the servo motor in ID32773 'Service bits' Bit 14.

7.5.3 Power plug round

NOTICE	
Material Damage!	<p>Damage to the rotatable right-angle connector!</p> <p>The angular connector can be rotated and aligned as desired with the plugged-in and screw-tightened mating connector (approx. 16 locking positions). For alignment, a torque of approx. >8 Nm is required. The alignment makes variable mounting positions and an adaptable motor connection possible.</p> <p>If the connector is frequently re-aligned, or aligned without a mating connector, by means of pliers or other tools, the thread of the screwcap can be destroyed and the sealing surface damaged.</p> <p>Steps to prevent:</p> <ul style="list-style-type: none"> • Only turn the connector if the mating connector is in place. • Do not use any pliers or other tools • The connector must not make any permanent movements. • To ensure that the protection class is upheld, max. 10 turns are permitted.

Description:

The power plug connector at the motor is connected with the power motor connection at the converter by means of the power cable. If necessary, equip the connection cable with twist, strain and shear relief, as well as kink protection. Forces that act on the connector permanently are not permissible!

Technical data:

The maximum permitted length of the cable is specified by the converter connection.

Design:

Type	Pins	Class
Power connector, metal, size 1	4+4	Built-in box with male contacts
Power connector, metal, size 1.5,	4+4	Built-in box with male contacts

Assignment of power plug, size 1

Drawing	Connection	Description
view of the mating connector 	A	Temperature sensor motor winding +
	B	Temperature sensor motor winding -
	C	Motor holding brake + / Fan
	D	Motor holding brake - / Fan
	1	Motor phase U
	3	Motor phase W
	4	Motor phase V
	PE	Protection earth

Assignment of power plug, size 1.5

Drawing	Connection	Signal	Description
view of the mating connector 	U	U	Motor phase U
	V	V	Motor phase V
	W	W	Motor phase W
	1	TH+	Temperature sensor motor winding +
	2	TH-	Temperature sensor motor winding -
	+	Br+	Motor holding brake + / Fan
	-	Br-	Motor holding brake - / Fan
	PE	PE	Protection earth

Connection

Cable	Shielded Power plug, size 1 $4 \times 1.5 \text{ mm}^2 + 2 \times (2 \times 0.34 \text{ mm}^2)$ $4 \times 2.5 \text{ mm}^2 + 2 \times (2 \times 0.75 \text{ mm}^2)$ $4 \times 4 \text{ mm}^2 + (2 \times 0.75 \text{ mm}^2) + (2 \times 1.0 \text{ mm}^2)$ Power plug, size 1.5 $4 \times 6 \text{ mm}^2 + (2 \times 0.75 \text{ mm}^2) + (2 \times 1.0 \text{ mm}^2)$ $4 \times 10 \text{ mm}^2 + (2 \times 0.75 \text{ mm}^2) + (2 \times 1.0 \text{ mm}^2)$ $4 \times 16 \text{ mm}^2 + (2 \times 2 \times 1.0 \text{ mm}^2)$
Shield connection	Apply on both sides
Accessories	prefabricated cables: Siehe 'Power Cable with power plug configured' auf Seite 69.

Circuit principle:

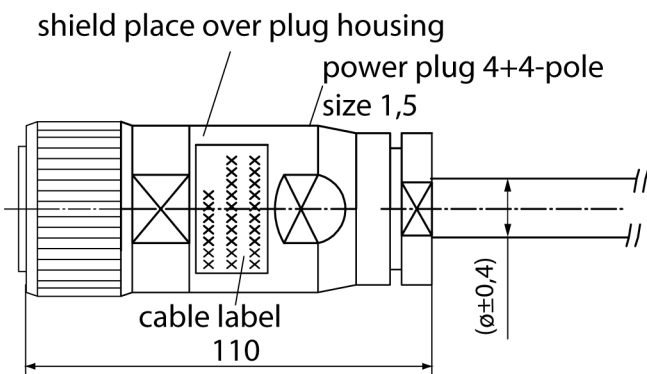
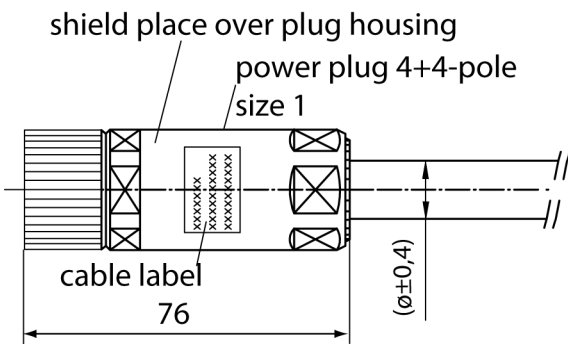

7.5.3.1 Power plug round - Siemens compliant

NOTICE

Material Damage!	Damage to the rotatable right-angle connector! The angular connector can be rotated and aligned as desired with the plugged-in and screw-tightened mating connector (approx. 16 locking positions). For alignment, a torque of approx. >8 Nm is required. The alignment makes variable mounting positions and an adaptable motor connection possible. If the connector is frequently re-aligned, or aligned without a mating connector, by means of pliers or other tools, the thread of the screwcap can be destroyed and the sealing surface damaged.
	Steps to prevent: <ul style="list-style-type: none"> • Only turn the connector if the mating connector is in place. • Do not use any pliers or other tools • The connector must not make any permanent movements. • To ensure that the protection class is upheld, max. 10 turns are permitted.

Description:

The power plug connector at the motor is connected with the power motor connection at the converter by means of the power cable. If necessary, equip the connection cable with twist, strain and shear relief, as well as kink protection. Forces that act on the connector permanently are not permissible!

Technical data:

The maximum permitted length of the cable is specified by the converter connection.

Design:

Type	Pins	Class
Power connector, metal, size 1	6	Built-in box with male contacts

Assignment of power plug, size 1

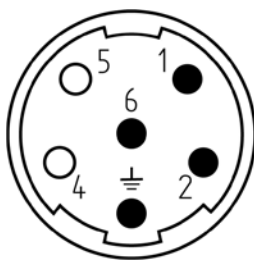
Drawing	Connection	Description
Front view of the device side 	1	Motor phase U
	2	Motor phase V
	4	Motor holding brake + / Fan
	5	Motor holding brake - / Fan
	6	Motor phase W
	PE	Protection earth

Design:

Type	Pins	Class
Power connector, metal, size 1.5,	4+2	Built-in box with male contacts

Assignment of power plug, size 1.5

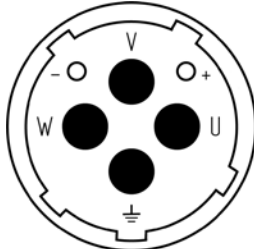
Drawing	Connection	Description
Front view of the device side 	U	Motor phase U
	V	Motor phase V
	W	Motor phase W
	+	Motor holding brake + / Fan
	-	Motor holding brake - / Fan
	PE	Protection earth

Connection

Cable	Shielded Power plug, size 1 4 x 1.5 mm ² + (2 x 0.34 mm ²) 4 x 2.5 mm ² + (2 x 0.75 mm ²) 4 x 4 mm ² + (2 x 1.0 mm ²) Power plug, size 1.5 4 x 6 mm ² + (2 x 1.0 mm ²) 4 x 10 mm ² + (2 x 1.0 mm ²) 4 x 16 mm ² + (2 x 1.0 mm ²)
Shield connection	Apply on both sides

7.5.3.2 Power plug round - PacDrive3 compliant

NOTICE	
Material Damage!	<p>Damage to the rotatable right-angle connector!</p> <p>The angular connector can be rotated and aligned as desired with the plugged-in and screw-tightened mating connector (approx. 16 locking positions). For alignment, a torque of approx. >8 Nm is required. The alignment makes variable mounting positions and an adaptable motor connection possible.</p> <p>If the connector is frequently re-aligned, or aligned without a mating connector, by means of pliers or other tools, the thread of the screwcap can be destroyed and the sealing surface damaged.</p> <p>Steps to prevent:</p> <ul style="list-style-type: none"> • Only turn the connector if the mating connector is in place. • Do not use any pliers or other tools • The connector must not make any permanent movements. • To ensure that the protection class is upheld, max. 10 turns are permitted.

Description:

The power plug connector at the motor is connected with the power motor connection at the converter by means of the power cable. If necessary, equip the connection cable with twist, strain and shear relief, as well as kink protection. Forces that act on the connector permanently are not permissible!

Technical data:

The maximum permitted length of the cable is specified by the converter connection.

Design:

Type	Pins	Class
Power connector, metal, size 1	4+4	Built-in box with male contacts

Assignment of power plug, size 1

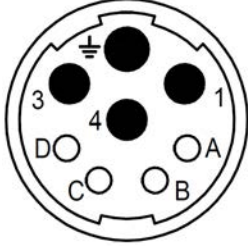
Drawing	Connection	Description
<p>Front view of the device side</p> 	1	Motor phase U
	3	Motor phase W
	4	Motor phase V
	A	Motor holding brake + / Fan
	B	Motor holding brake - / Fan
	C	Temperature sensor motor winding +
	D	Temperature sensor motor winding -
	PE	Protection earth

Design:

Type	Pins	Class
Power connector, metal, size 1.5,	4+2	Built-in box with male contacts

Assignment of power plug, size 1.5

Drawing	Connection	Description
Front view of the device side 	U	Motor phase U
	V	Motor phase V
	W	Motor phase W
	1	Temperature sensor motor winding +
	2	Temperature sensor motor winding -
	+	Motor holding brake + / Fan
	-	Motor holding brake - / Fan
	PE	Protection earth

Connection

Cable	Shielded Power plug, size 1 4 x 1.5 mm ² + (2 x 2 x 0.34 mm ²) 4 x 2.5 mm ² + (2 x 2 x 0.75 mm ²) 4 x 4 mm ² + (2 x 2 x 1.0 mm ²) Power plug, size 1.5 4 x 6 mm ² + (2 x 2 x 1.0 mm ²) 4 x 10 mm ² + (2 x 2 x 1.0 mm ²) 4 x 16 mm ² + (2 x 2 x 1.0 mm ²)
Shield connection	Apply on both sides

7.5.4 Power plug CM3

Description:

The power plug connector at the motor is connected with the power motor connection at the converter by means of the power cable. If necessary, equip the connection cable with twist, strain and shear relief, as well as kink protection. Forces that act on the connector permanently are not permissible!

Technical data:

The maximum permitted length of the cable is specified by the converter connection.

Design:

Type	Poles	Sort	Manufacturer	Designation
-	6	Female	ITT-Cannon	Insulator yellow for plug CM3 [X06.1]
-	4	Male	ITT-Cannon	Insulator black for plug CM3 [X06.2]

Assignment:

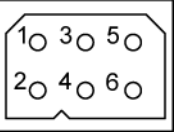
[X06.1] CM3-plug	Connection	Signal	Description
Front view of the device side 	1	TH+	Temperature sensor motor winding +
	2	TH-	Temperature sensor motor winding -
	3	-	-
	4	-	-
	5	Br+	Motor holding brake +
	6	Br-	Motor holding brake -

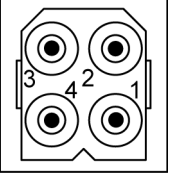
[X06.2] CM3-plug	Connection	Signal	Description
Front view of the device side 	1	U	Motor phase U
	2	V	Motor phase V
	3	W	Motor phase W
	4	PE	Protection earth

Siehe 'Handling of the CM3-plug (ITT-Cannon)' auf Seite 49.

Connection:

Mating plug	1 x 4-poles, female and 1 x 6-poles, male
Cable	Signal cable: 4 x 0,25 - 0,50 mm ² / AWG 24, shielded Motor power : 4 x 1 - 1,5 mm ² / AWG 18, shielded
Shield connection	Apply on both sides
Accessories	Prefabricated cables: in preparation

7.6 Hybrid connection

7.6.1 For your safety

⚠ DANGER



Danger to life from touching electrical connections!

Electrical terminals and connectors carry voltages that may cause death or serious injury upon contact.

Steps to prevent:

- Prior to any work on the device: Observe the 5 safety rules.
- Measure the terminal voltages. There may be no voltage present.
- Plug and pull connections only when there is no voltage.
- For devices that are connected to a DC bus, or generate it yourself, you need to consider the discharge times of the dc bus capacitors mentioned in the converter documentation
- Before commencing work, the connections must be isolated from the voltage supply at both ends! (both ends mean: AC and DC bus supply side)

⚠ DANGER



Danger to life from electrical shock!

In the event of an interruption to the PE connection, avoid touching the casing because life-threatening levels of voltage may be present!

Steps to prevent:

- EN 61800-5-1 requires that the devices be firmly connected on the power side.

⚠ DANGER	
	<p>Danger to life from touching electrical connections!</p> <p>The permanent magnets of the rotor induce dangerous voltage at the motor connections when the axis rotates, even when the motor is not electrically connected. If the motor is connected to an inverter, the induced DC voltage is linked to the terminals UZP and UZN for the DC bus.</p> <p>Steps to prevent:</p> <ul style="list-style-type: none"> • Make sure that the motor shaft does not rotate. • Make sure that shock-hazard protection is installed at the motor connections. • Make sure that the terminals are free of voltage.

7.6.2 Hybrid connector M15

NOTICE	
<p>Material Damage!</p>	<p>Material damage when plugging in the</p> <p>The plug must be aligned before insertion into the socket. The pin contacts are engaged before the codings of the plug and socket interlock. The pin contacts will be bent if the plug is turned when being inserted and the pin contacts are already engaged or if the plug and socket are not properly aligned and the screwcap is tightened.</p> <p>Steps to prevent:</p> <ul style="list-style-type: none"> • The plug must be inserted when aligned with the socket. • Only turn the plug if the pin contacts are not yet engaged. • Only tighten the screwcap once the codings of the plug and socket interlock.

Description

By means of a hybrid cable, the power supply of the motor as well as encoder are connected to the converter. The temperature sensor is connected internal to the encoder and the measured values are transmitted via Hiperface DSL.

If necessary, equip the connecting cables with strain and shear relief, anti-rotation and anti-kink protection. Forces constantly impacting on the plugs are not permitted.



Technical data

- Maximum line length: 100 m

Design

Type	Poles	Sort	Manufacturer	Designation
Receptacle	9	Male	intercontec	E EG A 201 NN 00 00 0501 000
Angled receptacle	9	Male	intercontec	E ED A 201 NN 00 00 0800 000

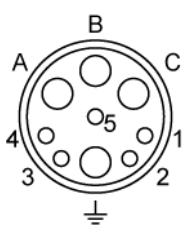
Assignment

Drawing	Connection	Signal	Description
<p>Front view, device side</p> 	A	U	Motor phase U
	B	V	Motor phase V
	C	W	Motor phase W
	1	+BR	+ Motor holding brake
	2	-BR	- Motor holding brake
	3	+DSL	+ Encoder signal Hiperface DSL
	4	-DSL	- Encoder signal Hiperface DSL
	5	-	not connected
	PE	Shield	

Connection

Mating plug (Type, manufacturer, designation)	Plug 9-poles female intercontec: E ST A 202 NN 00 34 0500 000
Cable	Hybrid cable DSL: twisted pair, shielded e. g. HELUKABEL or Tecni
Recommended cable cross section	4 x 0.5 mm ² +(2 x 0.34 mm ²)+(2 x AWG26)
Stripping length	Brake strands: 7 mm with connection to controller card KW-Rxx: X140
Shield connection	<p>Motor-side</p> <ul style="list-style-type: none"> • Connect over-all shield to the plug housing • Shields of the signal pairs insulated, no contact to the plug housing permitted <p>Converter-side</p> <ul style="list-style-type: none"> • Fold back the over-all shield and fix with shrink tube • Fold back the brake strand shield and fix with shrink tube • Connect the encoder strand shield to the housing of the D-Sub plug
Cable assembly	<p>Motor phases cable lug</p> <p>PE ring cable lug</p> <p>Encoder strands D-Sub plug 15-poles</p> <p>Assignment see interface description of the used controller card</p>
Accessories	Prefabricated cables: Siehe 'Hybrid cable configured' auf Seite 70.

Cable assembly

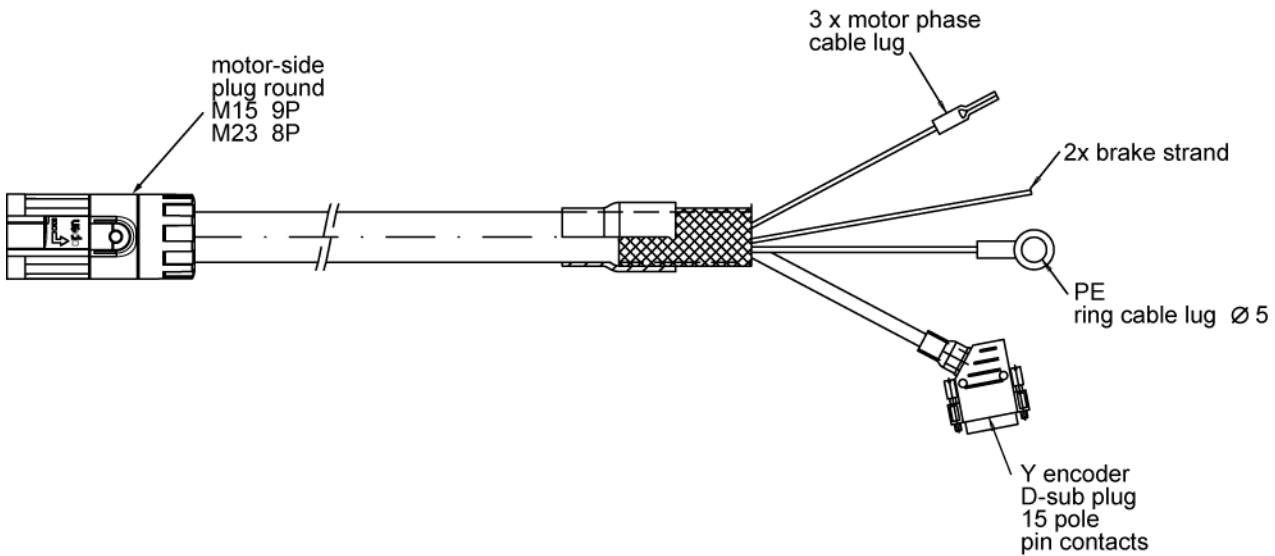

7.7 Handling of the CM3-plug (ITT-Cannon)

1. Remove the both screws and open the CM3-plug housing.

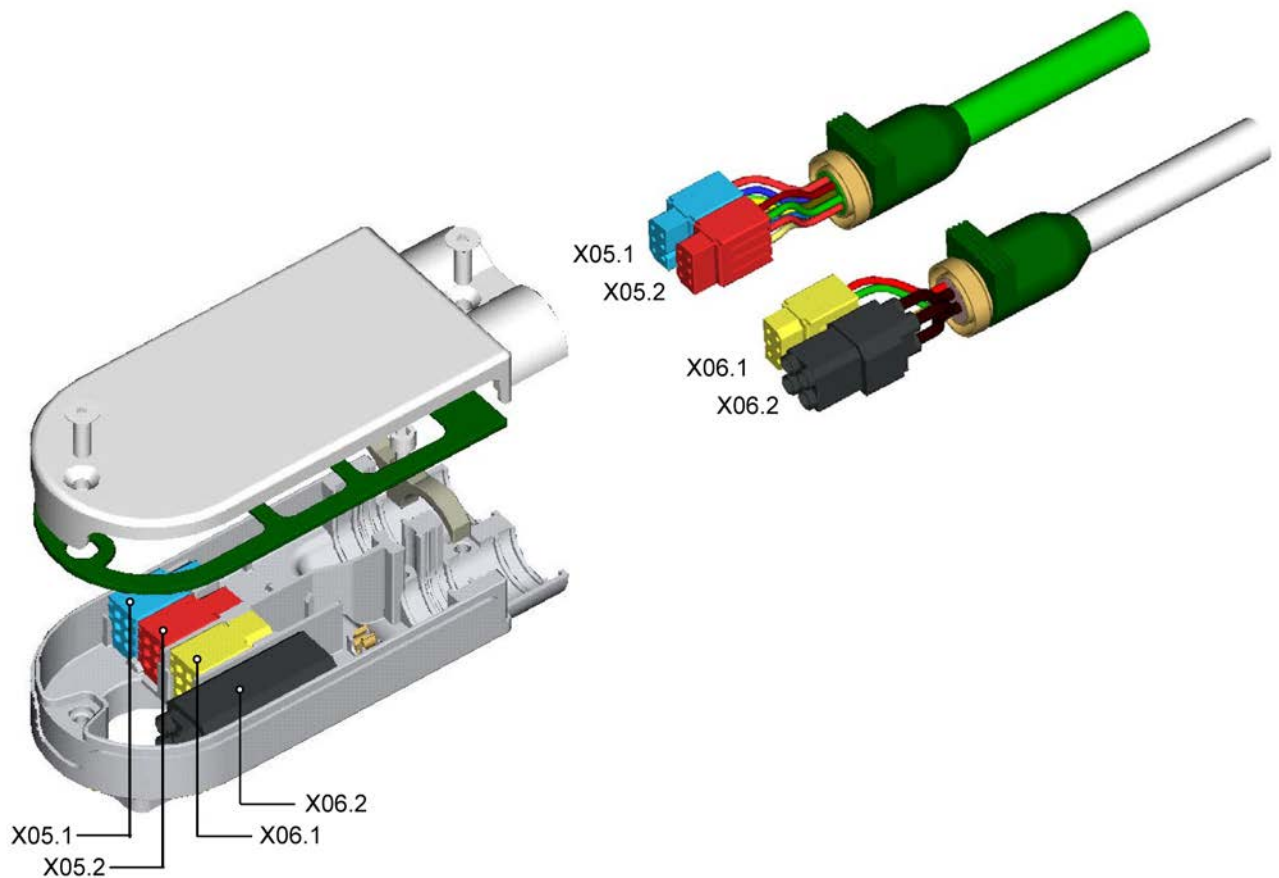

2. Remove the screw for the clamping bracket and remove the clamping bracket.
3. Lift the contacts with the insulator out of the CM3-plug housing.
4. Connect the lifted contacts with the mating plug of the motor and encoder cable.
5. Insert the connectors into the CM3-plug housing. Take care that the crimp sleeves of the cable and the isolators be in the guiding grooves .

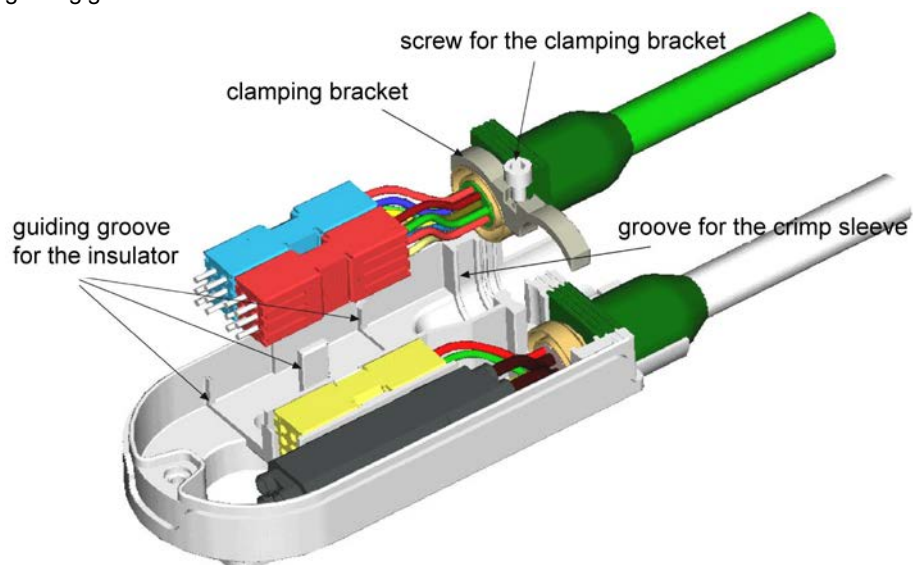

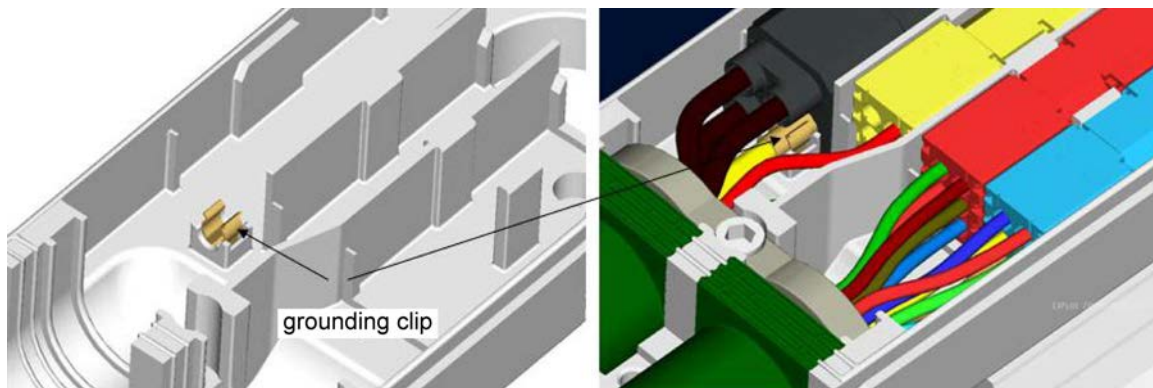

6. Take care that the grounding is done like shown in the following picture. (cable on the motor side are not shown)



7. Adjust the cable and screw tight the clamping bracket.
8. Screw the lid on the CM3-plug. Take care, that the sealing is not damaged.

8 Startup

8.1 For your safety

 DANGER	
	<p>Danger to life from touching electrical connections!</p> <p>Electrical terminals and connectors carry voltages that may cause death or serious injury upon contact.</p> <p>Steps to prevent:</p> <ul style="list-style-type: none">• Prior to any work on the device: Observe the 5 safety rules.• Measure the terminal voltages. There may be no voltage present.• Plug and pull connections only when there is no voltage.• For devices that are connected to a DC bus, or generate it yourself, you need to consider the discharge times of the dc bus capacitors mentioned in the converter documentation• Before commencing work, the connections must be isolated from the voltage supply at both ends! (both ends mean: AC and DC bus supply side)

⚠ DANGER**Motor shaft movement (rotating parts)!**

Hair, body parts and clothes can be captured and wrapped by rotating parts and people result suffer fatal injuries.

Hazardous motor movement occurs when the motor shaft moves in an uncontrolled or unintentional manner.

Even the intended drive movement may be hazardous, if persons remain inside the machine's range of movement.

Uncontrolled motor shaft movement occurs when the motor is no longer controllable. Depending on the type of machine, this may have lethal consequences. Possible causes include the following:

- Faulty wiring, e.g., faulty phase sequence while connecting motor
- Faulty encoder or components
- Faulty motor parameters
- Software error
- Faulty controlled commutation of the motor

Unintended motor shaft movement is caused by errors in the motor control. Depending on the type of machine, this may have lethal consequences. Possible causes include the following:

- Operator errors
- Controller or application program faults
- Faulty setpoint specification and scaling
- Improper operating mode

The monitoring devices in the drive system are capable of detecting various fault states. Their purpose is to reduce the drive speed to zero in a controlled manner before switching off the power supply. However, the monitoring devices by themselves are not sufficient to completely and reliably prevent uncontrolled movement. Uncontrolled movement cannot be prevented completely, even if it occurs only for a brief period of time before a monitoring device trips and shuts down the drive or switch off power supply.

Steps to prevent:

- Never allow personnel to remain in the vicinity of the machine while it is operating.
- Always ensure that the machine is fully de-energized before commencing work on the machine or within the machine's vicinity.
- Install an emergency off / stop switch.
- All suspended axles must be mechanically secured against falling down.
- Check the limit values for torque, speed, and position, as well as the acceleration and deceleration ramps.
- Specify the maximum permissible process speed and set ID113 accordingly.

⚠ DANGER**Risk of injury from hanging axes**

The optional motor brake is a holding brake and does NOT provide sufficient protection for persons.

Hanging axes can fall and lead to severe injury.

Steps to prevent:

- All hanging axes must be mechanically secured against falling with a fall arrester or a supplementary external brake, for instance.
- People must not stand under hanging loads

⚠ WARNING**Hazard due to changing parameters!**

The incorrect entering of parameters into the controller card significantly influences the drive system characteristics and creates an increased risk of accidents and damages!

Steps to prevent:

- Change parameters only if you are sure of the meanings and the consequences. If you are unsure, read the parameter documentation or ask the manufacturer or supplier.

⚠ WARNING**Risk of injury from loud noise!**

Servomotors can suddenly produce loud noises while operating, which affect your ears or cause frightful movements of the persons concerned. The noise is generated by resonance frequencies in conjunction with the driven mechanical parts.

Steps to prevent:

- build machine so or change that occur within the permissible operating range of the machine no resonant frequencies
- attach sound insulation
- setting up the machine in noise-sensitive areas

8.2 Avoiding material damage**NOTICE****Material Damage!****Material damage resulting from incorrect motor connection!**

The motors will be irreparably damaged if they are connected directly to the phases of the supply network without a converter.

Steps to prevent:

- Always operate the motor with a converter that is suitable for the motor and the application.
- Observe the information in the documentation of the converter.

NOTICE**Material Damage!****Material damage from defective liquid cooling!**

Motors that have been designed to be liquid-cooled are irreparably damaged by overheating when they are run without functional liquid cooling.

Fire hazard!

Steps to prevent:

- A motor designed for liquid cooling must never be operated without functional liquid cooling.
- Does the coolant circulation (flow rate, temperature) meet the specifications?
- Have the requirements to the coolant been fulfilled?
- Is there enough coolant in the circuit?
- Make sure that the required operating pressure is maintained.

8.3 Check list for preparing the startup

Check mechanical aspects:

- Have all components of the drive and the connecting elements been correctly mounted, installed and fastened?
- Have transport locks, covers and packaging been removed?
- Are the settings for the drive elements correct, depending on the type of element, e.g. coupling, belt tension, tooth flank, tip clearance for gear drive, radial play?
- Has the feather key, if equipped, been secured against being ejected?
- Can the rotor rotate freely without rubbing?
- Does the operating conditions match the specifications on the type plate?
- Are all components free of visible damage, e.g. caused by transport, storage, assembly?

Check electrical aspects:

- Have all earth connections and potential equalisation connections been correctly established?
- Have the electrical connections at the motor, converter and controller been correctly assigned and connected?
- Have the plug connections been secured against becoming loose?
- If a motor holding brake is equipped, is it working properly? (Does the brake open/close properly when operating voltage is switched on/off?)
- Are the speed and torque thresholds in the converter or the controller limited to the max. values permissible for the process, system or the mechanics built on?
The rated speed of the motor can be higher than that of the mechanical components or the gearbox. The speed threshold at which the converter or the controller switches off has to be set to the lowest permissible speed of the components involved in the process.

Check safety and monitoring devices:

- EMERGENCY STOP equipped and fully functional?
- Has the controller been configured in such a way that only setpoints are specified that are permissible for the process or the system?
- Are safety and monitoring devices active?

Parameterisation and drive configuration

- Has the drive system been configured to suit the application? (Parameter settings, e.g. limits, encoder database, closed-loop control settings, controller configuration, e.g. installing the program of the user)
- The PC software AIPEX PRO for configuration and startup of drive systems is available from AMK.
- Motor-specific parameter values you find on the specific motor data sheet and can be entered in the PC software AIPEX PRO.
- For motors with built-on mechanics (z. B. gearbox, screw), you must take care of, that the rated data of the mechanics and the motor are not exceeded.
- For motors, equipped with an encoder with electronic type plate, the motor specific parameter values are stored inside the motor encoder memory (see documentation 'Parameter description' ID32841 'Encoder list motor') and will be read from the converter automatically under certain conditions.

8.4 Switch-on



The motor is supplied with energy by means of the power infeed and the connected inverter. During switch-on, observe the instructions of the respective converter documentation.

Pay attention to the following during startup and operation

- Correct direction of rotation
- Unwanted speed fluctuations
- Loud noise
- Signs of overload
- Diagnostic messages of the connected converter

9 Operation

9.1 For your safety

 DANGER	
	<p>Danger to life from touching electrical connections!</p> <p>Electrical terminals and connectors carry voltages that may cause death or serious injury upon contact.</p> <p>Steps to prevent:</p> <ul style="list-style-type: none">• Prior to any work on the device: Observe the 5 safety rules.• Measure the terminal voltages. There may be no voltage present.• Plug and pull connections only when there is no voltage.• For devices that are connected to a DC bus, or generate it yourself, you need to consider the discharge times of the dc bus capacitors mentioned in the converter documentation• Before commencing work, the connections must be isolated from the voltage supply at both ends! (both ends mean: AC and DC bus supply side)

 **DANGER**



Motor shaft movement (rotating parts)!

Hair, body parts and clothes can be captured and wrapped by rotating parts and people result suffer fatal injuries.

Hazardous motor movement occurs when the motor shaft moves in an uncontrolled or unintentional manner.

Even the intended drive movement may be hazardous, if persons remain inside the machine's range of movement.

Uncontrolled motor shaft movement occurs when the motor is no longer controllable. Depending on the type of machine, this may have lethal consequences. Possible causes include the following:

- Faulty wiring, e.g., faulty phase sequence while connecting motor
- Faulty encoder or components
- Faulty motor parameters
- Software error
- Faulty controlled commutation of the motor

Unintended motor shaft movement is caused by errors in the motor control. Depending on the type of machine, this may have lethal consequences. Possible causes include the following:

- Operator errors
- Controller or application program faults
- Faulty setpoint specification and scaling
- Improper operating mode

The monitoring devices in the drive system are capable of detecting various fault states. Their purpose is to reduce the drive speed to zero in a controlled manner before switching off the power supply. However, the monitoring devices by themselves are not sufficient to completely and reliably prevent uncontrolled movement. Uncontrolled movement cannot be prevented completely, even if it occurs only for a brief period of time before a monitoring device trips and shuts down the drive or switch off power supply.

Steps to prevent:

- Never allow personnel to remain in the vicinity of the machine while it is operating.
- Always ensure that the machine is fully de-energized before commencing work on the machine or within the machine's vicinity.
- Install an emergency off / stop switch.
- All suspended axles must be mechanically secured against falling down.
- Check the limit values for torque, speed, and position, as well as the acceleration and deceleration ramps.
- Specify the maximum permissible process speed and set ID113 accordingly.

 **WARNING**



Risk of injury from loud noise!

Servomotors can suddenly produce loud noises while operating, which affect your ears or cause frightful movements of the persons concerned. The noise is generated by resonance frequencies in conjunction with the driven mechanical parts.

Steps to prevent:

- build machine so or change that occur within the permissible operating range of the machine no resonant frequencies
- attach sound insulation
- setting up the machine in noise-sensitive areas

⚠ WARNING**Danger caused by malfunctions and defects!**

Deviations from the normal operation, e.g. higher power consumption, temperature or vibrations, unusual noise, smells, tripped monitoring devices etc. indicate that the functionality has been affected. This can lead to malfunctions that could directly or indirectly lead to death, severe injury or material damage.

Steps to prevent:

- Immediately shut down the system.
- Contact the AMK customer service:
E-mail: service@amk-group.com
Telephone: +49 7021/50 05-190
Fax: +49 7021/50 05-193

⚠ WARNING**Risk of burns when touching hot surfaces!**

The casing temperatures of the motors can be more than 140 °C during operation and also after switch-off. Touching the surfaces results in burn injuries.

Steps to prevent:

- Make sure that the surfaces have cooled down.
- Wear protective clothing, e.g. gloves if you must touch hot parts.
- Place a warning message onto the product, which forewarns from touching.
- Do not mount highly flammable objects near to the motors.

9.2 Avoiding material damage**NOTICE****Material Damage!****Material damage resulting from Overheating!**

AMK servo motors are provided with sensors for temperature monitoring. Motors without or with bypassed sensors for temperature can overheat and be destroyed.

Steps to prevent:

- Connect the sensors for temperature of the servo motor for temperature monitoring
- Activate the I²t monitoring of the servo motor in ID32773 'Service bits' Bit 14.

9.3 Machine downtimes

In the event of machine downtimes of more than 4 weeks, we recommend starting up the machine once a month or rotating the rotor shaft.

10 Diagnostics

Observation	Possible cause	Remedy measures
Motor does not develop any torque and does not start.	Power supply interrupted	Check connections and wiring; measure the supply voltage
	One of the phases interrupted in the supply line / motor winding	Check the inverter and power supply of the motor; determine the winding resistances and insulation resistances in agreement with the AMK customer service
	Error in converter	Read out the diagnostic number
	Incorrect parameters	Check parameters, e.g. torque limits, operating mode, setpoint specifications
Motor drones and has a high current consumption Motor does not start, or only with difficulty	Motor blocked	Make sure the motor is de-energised and, with the brake opened, check whether the shaft and equipped power transmission elements can move/rotate freely.
	Motor overload	Reduce load
	Brake does not open	See observation "Brake does not open"
	Malfunction in the signal feedback of the encoder	Check the encoder cable and signals
	Motor parameters are incorrect	Check the setting for the motor type; check the group of motor parameters for correct parameterisation
	Winding short circuit or phase-to-phase fault in the stator winding	Determine the winding resistances and insulation resistances, contact the AMK customer service
	One of the phases interrupted in the supply line/motor winding	Check the inverter and power supply of the motor; under consultation with the AMK customer service, determine the winding resistances and insulation resistances
Disturbed setpoint	Check setpoint and commanding	
Motor makes uncontrolled movements	Incorrect motor parameters Error in encoder signal feedback	Check the setting for the motor type; check the group of motor parameters for correct parameterisation
	Disturbed setpoint	Check setpoint and commanding
Wrong direction of rotation	Wrong polarity	Is the phase sequence of the motor connections correct? In the parameter settings, check the setpoints, control circuit polarities, settings for the direction of rotation
Radial vibrations	Rotor out of balance	Decouple the rotor from the load and check whether the imbalance is caused by the motor or by the load.
	Rotor out of true; shaft bent	Contact the AMK customer service
	Drive elements or motor not properly aligned	Re-align components
	Coupled load out of balance	Rebalance and align the coupled load and check whether the imbalance is caused by the motor or by the load.
	Imbalance originating from gearing or load	Check runout of gearing or of the load
Axial vibrations	Drive elements or motor not properly aligned	Re-align components
	Shocks from coupled machine	Check coupled machine
	Imbalance originating from gearing	Check runout of gearing
Running noises at / in the motor	Bearing damage	Contact the AMK customer service
	Vibration of rotating parts	Eliminate the cause and the imbalance
	Rotating parts are grinding	Rework the parts concerned
	Loose parts / foreign items in the motor	Contact the AMK customer service

Observation	Possible cause	Remedy measures
Motor gets too hot	Drive overload Rated data as per EN 60034 exceeded, e.g. too high effective torque	Measure power, reduce load, check motion profile, check drive configuration, use larger motor
	Ambient temperature too high	Observe permissible temperature range
	Inadequate cooling	Check efficiency of cooling Is surface dirty?
	Optimise parameterisation in inverter	Check motors and control parameters; adapt speed and torque limits
Brake does not open	Brake not correctly connected	Check brake connections
	Max. permissible air gap of the brake exceeded	Contact the AMK customer service
	Short circuit in the coil or at body of brake coil	Contact the AMK customer service
No or too low holding torque, although brake is engaged	Brake pads worn	Contact the AMK customer service
	Adjust air gap	Contact the AMK customer service
Noise (squeaking) in the brake area	Brake parameters incorrectly configured in the inverter	Check the brake opening and closing times ID206 'Drive on delay time' ID207 'Drive off delay time'
	Mechanical defect	AMK customer service
Motor brake does not hold	Brake pads worn	Contact the AMK customer service
Overheating of individual winding sections	Winding short circuit or phase-to-phase fault in the stator winding	Determine the winding resistances and insulation resistances, contact the AMK customer service DC-operation mode
Uneven running	Inadequately shielded motor cable and encoder cable	Check shielding and earth
	Amplification of the drive controller too large	Check and adapt controller parameters
	Mechanics	check mechanics

AMK customer service:

E-mail: service@amk-group.com

Telephone: +49 7021/50 05-190

Fax: +49 7021/50 05-193

11 Maintenance and repair

11.1 For Your safety

 **DANGER**



Danger to life from touching electrical connections!

Electrical terminals and connectors carry voltages that may cause death or serious injury upon contact.

Steps to prevent:

- Prior to any work on the device: Observe the 5 safety rules.
- Measure the terminal voltages. There may be no voltage present.
- Plug and pull connections only when there is no voltage.
- For devices that are connected to a DC bus, or generate it yourself, you need to consider the discharge times of the dc bus capacitors mentioned in the converter documentation
- Before commencing work, the connections must be isolated from the voltage supply at both ends! (both ends mean: AC and DC bus supply side)

 **DANGER**



Danger to life from touching electrical connections!

The permanent magnets of the rotor induce dangerous voltage at the motor connections when the axis rotates, even when the motor is not electrically connected. If the motor is connected to an inverter, the induced DC voltage is linked to the terminals UZP and UZN for the DC bus.

Steps to prevent:

- Make sure that the motor shaft does not rotate.
- Make sure that shock-hazard protection is installed at the motor connections.
- Make sure that the terminals are free of voltage.

⚠ DANGER**Motor shaft movement (rotating parts)!**

Hair, body parts and clothes can be captured and wrapped by rotating parts and people result suffer fatal injuries.

Hazardous motor movement occurs when the motor shaft moves in an uncontrolled or unintentional manner.

Even the intended drive movement may be hazardous, if persons remain inside the machine's range of movement.

Uncontrolled motor shaft movement occurs when the motor is no longer controllable.

Depending on the type of machine, this may have lethal consequences. Possible causes include the following:

- Faulty wiring, e.g., faulty phase sequence while connecting motor
- Faulty encoder or components
- Faulty motor parameters
- Software error
- Faulty controlled commutation of the motor

Unintended motor shaft movement is caused by errors in the motor control. Depending on the type of machine, this may have lethal consequences. Possible causes include the following:

- Operator errors
- Controller or application program faults
- Faulty setpoint specification and scaling
- Improper operating mode

The monitoring devices in the drive system are capable of detecting various fault states. Their purpose is to reduce the drive speed to zero in a controlled manner before switching off the power supply. However, the monitoring devices by themselves are not sufficient to completely and reliably prevent uncontrolled movement. Uncontrolled movement cannot be prevented completely, even if it occurs only for a brief period of time before a monitoring device trips and shuts down the drive or switch off power supply.

Steps to prevent:

- Never allow personnel to remain in the vicinity of the machine while it is operating.
- Always ensure that the machine is fully de-energized before commencing work on the machine or within the machine's vicinity.
- Install an emergency off / stop switch.
- All suspended axes must be mechanically secured against falling down.
- Check the limit values for torque, speed, and position, as well as the acceleration and deceleration ramps.
- Specify the maximum permissible process speed and set ID113 accordingly.

**⚠ DANGER****Danger from magnetic and electromagnetic fields**

Magnetic and electromagnetic fields can be dangerous for people with pacemakers, implants and electronic hearing aids, because the correct functioning of these devices can be interfered with by magnetic and electromagnetic fields.

Permanent magnets, such as in synchronous motors, create magnetic fields. Current-carrying leads are generally surrounded by electromagnetic fields.

Steps to prevent:

- Persons with pacemakers, hearing aids or metallic implants may not enter the following areas without a doctor's approval:
 - Places where electrical drives are commissioned and operated
 - Places where permanent magnets and rotor shafts are stored, mounted and fitted with permanent magnets for electric motors.
 - Places where electric motors with permanent magnets are opened. (Only an electric motor with closed housing shields its inner electromagnetic fields with respect to the environment.)



⚠ WARNING



Risk of burns when touching hot surfaces!

The casing temperatures of the motors can be more than 140 °C during operation and also after switch-off. Touching the surfaces results in burn injuries.

Steps to prevent:

- Make sure that the surfaces have cooled down.
- Wear protective clothing, e.g. gloves if you must touch hot parts.
- Place a warning message onto the product, which forewarns from touching.
- Do not mount highly flammable objects near to the motors.

11.2 Avoiding material damage

Defective AMK components must be sent to AMK for appraisal and repairs. Repair work may only be performed by qualified personnel authorised by AMK GmbH und Co.KG. For personnel not authorised by AMK, it is forbidden to open and/or modify the units in any way. Failure to comply with this requirement shall immediately void the warranty. In these cases, AMK assumes no liability for any subsequent damages. Only original parts of AMK GmbH und Co.KG may be used for repairs.

11.3 Screw nut

11.3.1 Dismounting

NOTICE

Material Damage!

Soiling will damage the screw nut

Soiling entering the screw nut will damage the circulating balls and the raceways.

Steps to prevent:

- Make sure to keep the screw nut clean when dismounting it.

If it is necessary to dismount the screw nut from the screw, you have to use a fitting sleeve (siehe 'Dimensional drawings' auf Seite 20).

The fitting sleeve has constantly to lie flat against the beginning of the thread until the screw nut is transferred to the fitting sleeve. The journal of the screw can be used to centre the fitting sleeve.

Rotate the screw nut carefully from the screw thread to the fitting sleeve.

O-rings at the ends of the fitting sleeve prevent the screw nut from slipping off the fitting sleeve.

When remounting the screw nut to the screw, carefully screw it into the beginning of the thread so that deflectors and sealings are not damaged.

11.3.2 Re-lubrication

The lubrication intervals depend on several influences as there are time of operation, stroke length, acceleration, soiling, operating and environmental temperatures etc.

In general the screw nut must be re-lubricated every 200 - 600 hours of operation under standard conditions.

Standard conditions:

- Load relation: max. 20 % of the dynamic load rating C dyn. (C dyn. from the screw data of the motor data sheet)
- Temperature range: 0 °C ... 60 °C
- Speed characteristic: DN < 120.000
(DN = d x n_{max}; d = nominal diameter [mm], n_{max} = max. speed [1/min])
- No shocks or vibrations



Different conditions or soiling will shorten the lubrication intervals.

Lubricant quantity for ball screw drives with grease lubrication

	Ball screw drive	Lubrication quantity [cm ³]	
		Initial lubrication	Re-lubrication
SEZ 3	KGT 16x05	0,2 (3x)	0,4
	KGT 16x10	0,4 (3x)	0,8
	KGT 16x16	0,3 (3x)	0,6
SEZ 4	KGT 25x05	0,6 (3x)	1,2
	KGT 25x10	0,7 (3x)	1,4
	KGT 25x25	0,8 (3x)	1,6

Recommended greases:

- Klüber Klüberquiet® BQH 72-102
- Klüber ISOFLEX® TOPAS NCA 52



If the ball screw drives are installed vertically, the lubricant quantity has to be increased by about 50 %.



You will get information about grease types and lubrication intervals from the respective motor data sheet.

11.4 Exchanging an absolute encoder

A servo motor can only be controlled if the rotary fields of the rotor and stator are matched. In synchronous motors, the rotary field of the rotor is determined by the permanent magnets. The relation between the rotary fields of the rotor and stator is determined for each motor after assembly, by means of encoder tuning, and is saved in the encoder. To correctly supply the motor with current, the converter reads the value determined during the encoder tuning from the encoder.

If the absolute encoder is replaced or its position on the motor shaft is changed, the encoder tuning has to be performed again prior to startup.

11.5 Maintenance intervals

Diligent regular inspections and maintenance help to detect malfunctions early and remedy them before consequential damage occurs. If malfunctions, unusual loads or conditions occur that might negatively affect the drive system, e.g. overload, short circuit or mechanical damage, the components of the drive system have to be checked immediately.

The intervals for maintenance tasks are very dependent on the local conditions at the location where the drive system is in use, e.g. dirt, load, how frequently it is switched on, etc.

The following table gives a general overview of the maintenance measures and intervals. The measures and the specified intervals have to be adapted to the respective conditions and supplemented as necessary.

Measures	Maintenance interval
Cleaning the surfaces	Directly dependent on the degree of soiling; heavy soiling interferes with the proper heat dissipation of the components.
Visual inspections of cables and connections	Regularly check connection cables for damage, and replace if necessary. Do not make provisional repairs to the connection lines. If any damage is visible on the sheathing, no matter how small, immediately shut down the system and renew the cables.
Visual inspections of housings, leaks	Check regularly.
Exchanging the bearings	If the motor is run with the rated data, we recommend exchanging the bearings after 40,000 operating hours. If the bearing is subjected to axial and radial forces, the service life is reduced as shown by the characteristic curve on the motor data sheet. In vertical installation position, the grease service life stated in the data sheet is reduced by half.
Exchanging the radial shaft seal rings	Parallel to the bearing change, every 40,000 h

Measures	Maintenance interval
Re-lubrication intervals	You can find a reference value for the re-lubrication intervals of the axial bearings on the motor/motor data sheet. The re-lubrication intervals heavily depend on the motion profile actually traversed and the cycle times. The B-side bearing is lubricated for life and needs no maintenance.
Replacing the encoder belt, if applicable	20,000 h
Lubrication change, performed by AMK	If motors were in storage for more than 2 years, we recommend a lubrication change.

11.6 Cleaning

Dirt, dust, or shavings on the motor surface reduce the radiation of heat in **convection-cooled motors**. Regularly clean the motor surface with compressed air, a wet cloth and neutral cleaning agent, as necessary.



The functionality of **liquid-cooled drives** is not impaired by soiling. However, to prevent dirt from penetrating into the motor, we recommend also keeping these motor surfaces clean.

Make sure that no moisture gets into the motor during the cleaning process!

A high-pressure jet of water can damage seals and cause water to get into the machine. This can damage the motor and could result in consequential errors.

12 Decommissioning and disposal

12.1 For your safety

 DANGER	
	<p>Danger from magnetic and electromagnetic fields</p> <p>Magnetic and electromagnetic fields can be dangerous for people with pacemakers, implants and electronic hearing aids, because the correct functioning of these devices can be interfered with by magnetic and electromagnetic fields.</p> <p>Permanent magnets, such as in synchronous motors, create magnetic fields. Current-carrying leads are generally surrounded by electromagnetic fields.</p> <p>Steps to prevent:</p> <ul style="list-style-type: none"> • Persons with pacemakers, hearing aids or metallic implants may not enter the following areas without a doctor's approval: <ul style="list-style-type: none"> • Places where electrical drives are commissioned and operated • Places where permanent magnets and rotor shafts are stored, mounted and fitted with permanent magnets for electric motors. • Places where electric motors with permanent magnets are opened. (Only an electric motor with closed housing shields its inner electromagnetic fields with respect to the environment.)

12.2 Preparing disassembly

- Ask your local waste disposal company what you need to observe during disposal.
- Observe the 5 safety rules
- Remove all electrical connections and cables
- Remove all liquids, e.g. oil, coolant
- Loosen the fastenings of the motors.

12.3 Disposing of the materials

Clarify with your local waste disposal company which materials and chemicals need to be separated and how to dispose of them. Observe the local regulations for disposal.

Examples of materials to be disposed of separately:

Components

- Electronic scrap, e. g., encoder electronics
- Iron scrap
- Aluminium
- Non-ferrous metal, e. g., motor windings
- Insulating materials

Chemicals

- Oils (disposal as hazardous waste, in acc. with the pertinent legislation; in Germany, the Waste Oil Ordinance (AltöIV) applies)
- Grease
- Solvents
- Paint residue
- Coolant

13 Technical data

13.1 General technical data

Motor type:	Synchronous servo motor with permanent magnet
Ambient temperature:	+5 to +40°C. At higher ambient temperatures of up to maximum 60°C, the rated data must be reduced by 1% per 1 K temperature increase.
Installation height acc. to EN 60034-1 (IEC 60034-1):	Up to 1000 m above sea level (NHN).
Humidity:	Maximum 85% relative humidity, no condensation.
Protection class acc. to EN 60034-5 (IEC60034-5):	IP 54 Higher protection classes are indicated on the data sheet or are available on request.
Rated data:	Relative to the temperature rise in windings, in Kelvin: DT motors: 80 K Here the motor is mounted on a 500 mm x 500 mm x 10 mm steel flange that approximates the thermal properties at the machines and systems as closely as possible.
Vibration acc. EN 60068-2-6:	20g (55..2000 Hz)
Shock acc. EN 60068-2-27:	100g
Insulation class of the stator winding acc. to EN 60034-1 (IEC 60034-1) DIN 57530:	F (maximum permissible continuous temperature 155 °C)
Temperature monitoring acc. to EN 60034-11 (IEC 60034-11):	PTC thermistor, cold resistance approx. 150-800 Ohm or KTY 84 temperature sensor
Motor bearing:	Ball bearing, lubricated-for-life; else observe the information on motor/motor data sheet
Axial runout, radial runout acc. to (IEC 60072-1):	Tolerance N (normal)
Balance quality grade acc. to DIN ISO 1940:	G 2,5
Vibration quality acc. to DIN ISO 2373:	N
Vibration severity grade acc. to EN 60034-14:	Grade A is maintained up to the rated speed
Paint:	RAL 9005, jet black, matt
Sound pressure level:	acc. to DIN EN ISO 1680
Cooling:	Depending on motor type: Convection-cooled
Model type acc. to EN 600034-7 (IEC 60034-7):	IM B5
Motor encoder:	Integrated
Brake:	Optional integrated motor holding brake

13.2 Motor data

You can get the motor-specific data from the respective motor data sheet:

- Motor description
- Performance data
- Performance characteristics
- Electrical data
- Controller settings
- Mechanical data
- Brake data (optional)
- Fan data (optional)
- Thermistor
- Screw data
- Axial load diagram
- Encoder data
- Remarks

14 Accessories

14.1 Encoder connection M23

14.1.1 Encoder plug set

Designation	AMK part no.	Description
Encoder plug set, straight	49163	Plug set + assembly manual
Encoder plug set, angled	49362	Plug set + assembly manual

14.1.2 Encoder cable with M23-plug configured

Designation	AMK part-no.	Description
Encoder cable E-, F-, P-, Q-, I-encoder, M23 / CM3	403118	Length y m ³), for E-, F-, P-, Q-, I-encoder, suitable for trailing chain ²⁾ Configuration side 1: blue and red insulator, each 6-poles, male, for CM3-plug Configuration side 2: M23, female, 12-poles, for M23 encoder plug
Encoder cable S-, T-, U-, V-encoder, M23 / CM3	403182	Length y m ³), for S-, T-, U-, V-encoder, suitable for trailing chain ²⁾ Configuration side 1: blue and red insulator, each 6-poles, male, for CM3-plug Configuration side 2: M23, female, 12-poles, for M23 encoder plug
Encoder cable S-, T-, U-, V-encoder, M23 / D-Sub15	101612	Length y m ³), for S-, T-, U-, V-encoder, suitable for trailing chain ²⁾ Configuration side 1: D-Sub 15-poles, male Configuration side 2: M23 female, 12-poles, plug straight, for M23 encoder plug
Encoder cable S-, T-, U-, V-encoder, M23 angled / D-Sub15	101614	Length y m ³), for S-, T-, U-, V-encoder, suitable for trailing chain ²⁾ Configuration side 1: D-Sub 15-poles, male Configuration side 2: M23 female, 12-poles, plug angled, for M23 encoder plug
Encoder cable E-, F-, P-, Q-encoder, M23 / D-Sub15	101613	Length y m ³) for E-, F-, P-, Q-encoder, suitable for trailing chain ²⁾ Configuration side 1: D-Sub 15-poles, male Configuration side 2: M23 female, 12-poles, plug straight, for M23 encoder plug
Encoder cable E-, F-, P-, Q-encoder, M23 angled / D-Sub15	101615	Length y m ³), for E-, F-, P-, Q-encoder, suitable for trailing chain ²⁾ Configuration side 1: D-Sub 15-poles, male Configuration side 2: M23 female, 12-poles, plug angled, for M23 encoder plug
Encoder cable P-, Q-encoder (without analogue tracks) M23 / D-Sub9	401156	Length y m ³), for P-, Q-encoder (without analogue tracks), suitable for trailing chain ²⁾ Configuration side 1: D-Sub 9-poles, male Configuration side 2: M23 female, 12-poles, plug straight, for M23 encoder plug
Encoder cable P-, Q-encoder (without analogue tracks) M23 angled / D-Sub9	401157	Length y m ³), for P-, Q-encoder (without analogue tracks), suitable for trailing chain ²⁾ Configuration side 1: D-Sub 9-poles, male Configuration side 2: M23 female, 12-poles, plug angled, for M23 encoder plug

Designation	AMK part-no.	Description
Encoder cable I-encoder M23 / D-Sub15	101763	Length y m ³⁾ , for I-encoder, suitable for trailing chain ²⁾ Configuration side 1: D-Sub 15-poles, male Configuration side 2: M23 female, 12-poles, plug straight, for M23 encoder plug
Encoder cable I-encoder M23 angled / D-Sub15	101764	Length y m ³⁾ , for I-encoder, suitable for trailing chain ²⁾ Configuration side 1: D-Sub 15-poles, male Configuration side 2: M23 female, 12-poles, plug angled, for M23 encoder plug
Encoder cable resolver M23 / D-Sub9	101761	Length y m ³⁾ , for R-encoder, suitable for trailing chain ²⁾ Configuration side 1: D-Sub 9-poles, male Configuration side 2: M23 female, 12-poles, plug straight, for M23 encoder plug
Encoder cable resolver M23 angled / D-Sub9	101762	Length y m ³⁾ , for R-encoder, suitable for trailing chain ²⁾ Configuration side 1: D-Sub 9-poles, male Configuration side 2: M23 female, 12-poles, plug angled, for M23 encoder plug

- 1) Bend radius: 85 mm
Bend cycles: 2000000
- 2) Bend radius: 12 x outer diameter of the cable
Bend cycles: 5000000
- 3) The cable can be ordered in the desired length by the part-no. above.

14.2 Encoder cable with CM3 plug configured

Designation	AMK part no.:	Description
Encoder cable E-, F-, P-, Q-, S-, T-, U-, V-type encoder	403344	CM3 / CM3; 1:1 ¹⁾ Suitable for trailing chain; bend radius: 12 x outer diameter of the cable The cable can be ordered in the desired length by the part-no.

- 1) For different configuration, please contact your AMK representative

14.3 Power connection M23

14.3.1 Power plug set

Designation	AMK part no.	Description
Power plug set up to 16 A, size 1	48226	For cable cross-sections of 0.75 mm ² , 1.5 mm ² , 2.5 mm ²
Power plug set up to 25 A, size 1	48286	For cable cross-sections of 4.0 mm ²
Power plug set up to 36 A, size 1.5	48468	For cable cross-sections of 6.0 mm ² , 10.0 mm ²
Power plug set up to 75 A, size 1.5	103624	For cable cross-sections of 6.0 mm ² - 16.0 mm ²

14.3.2 Power Cable with power plug configured

Designation	AMK part no.	Description
AM-GA-Q1,5-...MS ¹⁾	18570	<ul style="list-style-type: none"> • Connecting cable for motor • With size 1 power plug • Preassembled cables for power, temperature sensor and brake • With straight plug • Suitable for trailing chain use²⁾ • On the connection side for converters, the cables have been stripped, and the shielding folded back and secured with heat-shrinkable sleeves. • Different cross-sections, e.g. Q1,5 equals 1.5 mm².
AM-GA-Q2,5-...MS ¹⁾	19376	
AM-GA-Q4-...MS ¹⁾	19216	

Designation	AMK part no.	Description
AM-GA-Q6-...MS ¹⁾	19377	<ul style="list-style-type: none"> Connecting cable for motor With power plug, size 1.5 Preassembled cables for power, temperature sensor and brake With straight plug Suitable for trailing chain use On the connection side for the converters, the cables have been stripped, and the shielding folded back and secured with heat-shrinkable sleeves. The cable ends have been equipped with end sleeves or cable lugs. Different cross-sections, e.g. Q6 equals 6 mm².
AM-GA-Q10-...MS ¹⁾	19378	
AM-GA-Q16-...MS ¹⁾	400186	

1) For "...", enter the desired cable length in metres (min. length 2 m, in increments of 1 m).

2) Bend radius: 7.5 x outer diameter, except cable AMK part no. 18570: bend radius: 15 x outer diameter cable
Bend cycles: 500000

Assignment of power plug, size 1 (Q1,5 - Q4)

Connection	Description	Lead marking at AMK part-no.
		18570, 19376 and 19216
A	Temperature sensor motor winding +	white/5
B	Temperature sensor motor winding -	brown/6
C	Motor holding brake +	green/7
D	Motor holding brake -	yellow/8
1	Motor phase U	L1 / U
3	Motor phase W	L3 / W
4	Motor phase V	L2 / V
PE	Protective conductor	green/yellow

Assignment of power plug, size 1,5 (Q6 - Q16)

Connection	Description	lead marking at AMK part-no.
		19377, 19378 and 400186
1	Temperature sensor motor winding +	5
2	Temperature sensor motor winding -	6
+	Motor holding brake +	7
-	Motor holding brake -	8
U	Motor phase U	1
W	Motor phase W	3
V	Motor phase V	2
PE	Protective conductor	green/yellow

14.4 Power cable with CM3-plug configured

Designation	AMK part-no.:	Description
Motor cable	403345	CM3 / CM3; 1:1 ¹⁾ Suitable for trailing chain; bend radius: 12 x outer diameter of the cable The cable can be ordered in the desired length by the part-no.

1) For different configuration, please contact your AMK representative

14.5 Hybrid cable configured

Designation	AMK part-no.	Description
Hybrid cable Q0,5 DSL	403550	Y-type encoder, M15 9-poles, power wire cross-section 0,5 mm ² The cable can be ordered in the desired length by the part-no.

15 Certificates

The certificates are available through AMKmotion sales or on the AMKmotion website.

- Declaration of conformity

You can get it as follows:

- AMKmotion homepage - service - download - registration - start online documentation - certificates
(One-time manual activation by AMKmotion sales department is necessary.
The auto-registration via AMKmotion homepage does not include access to the entire documentation.)

www.amk-motion.com/en/content/download_area



Glossary

A

AIPEX

AMK startup and parameterizing software (PC software): Programming, parameterization, configuration, diagnosis, oscilloscope, status information

AWG

American Wire Gauge (Coding of wire diameter)

E

E-encoder

Absolute encoder, singleturn, EnDAT 2.1 with additional sine and cosine track

EMV

Electromagnetic compatibility

EMC

Electromagnetic compatibility

EnDat 2.1

Motor encoder interface protocol of the company Heidenhain

EnDat 2.2

Motor encoder interface protocol of the company Heidenhain

F

F-encoder

Absolute encoder, multiturn, EnDAT 2.1 with additional sine and cosine track

G

GND

Ground potential

H

Hiperface

Motor encoder interface protocol of the company Sick Stegmann

Hiperface DSL

Motor encoder interface protocol of the company Sick Stegmann

I

i^2t

Integral of the squared current over time

ID

Parameter identification numbers acc. to SERCOS Standard

K

KTY

Type of a temperature sensor

N

NHN

Heights measured above the base height levelReference plane for heights over the sea level for Germany since 1992. The reference plane is located in Germany on the church in Wallenhorst.

P

PDK_XXXXXX_abcdefgh

Product documentation; XXXXXX - AMK part no. , abcdefgh - name

P-encoder

Absolute encoder singleturn, EnDAT 2.2 light

Q

Q-encoder

Absolute encoder multiturn, EnDAT 2.2 light

R

R-encoder

Absolute angle encoder singleturn (1 sine and cosine track per rotation)

Resolver

Absolute angle encoder singleturn (1 sine and cosine track per rotation)

S

S-encoder

Absolute encoder, singleturn, RS485 Hiperface with sine and cosine track

T

T-encoder

Absolute encoder, multiturn, RS485 Hiperface with sine and cosine track

U

U-encoder

Absolute encoder, singleturn, RS485 Hiperface with sine and cosine track

UZN

DC bus voltage pole negative

UZP

DC bus voltage pole positive

V**V-encoder**

Absolute encoder, multiturn, RS485 Hiperface with sine and cosine track

Y**Y-encoder**

Absolute encoder, singleturn or multiturn, RS485 Hiperface DSL

Your opinion is important!

With our documentation we want to offer you the highest quality support in handling the AMKmotion products.

That is why we are now working on optimizing our documentation.

Your comments or suggestions are always of interest to us.

We would be grateful if you take a bit of time and answer our questions. Please return a copy of this page to us.



e-mail: Documentation@amk-motion.com

or

fax no.: +49 7021/50 05-199

Thank you for your assistance.

Your AMKmotion documentation team

1. How would you rate the layout of our AMKmotion documentation?

(1) very good (2) good (3) satisfactory (4) less than satisfactory (5) poor

2. Is the content structured well?

(1) very good (2) good (3) moderate (4) hardly (5) not at all

3. How easy is it to understand the documentation?

(1) very easy (2) easy (3) moderately easy (4) difficult (5) extremely difficult

4. Did you miss any topics in the documentation?

(1) no (2) if yes, which ones:

5. How would you rate the overall service at AMKmotion?

(1) very good (2) good (3) satisfactory (4) less than satisfactory (5) poor

AMKmotion GmbH + Co KG

Phone : +49 7021/50 05-0, fax: +49 7021/50 05-199

E-Mail: info@amk-motion.com

Homepage: www.amk-motion.com